

# Ⓢ User Manual

i3

ANYCUBIC

Thank you for choosing **ANYCUBIC** products!



Please read the user manual carefully.



Please visit [www.anycubic3d.com](http://www.anycubic3d.com) for more information.



Email us on [support@anycubic3d.com](mailto:support@anycubic3d.com) or [james@anycubic3d.com](mailto:james@anycubic3d.com) for technical support.

Copyrighted by "Shenzhen Anycubic Technology Co., Ltd ", all rights reserved.



**ANYCUBIC** Website



Facebook account



YouTube channel



Team **ANYCUBIC**

# Safety instruction



**ANYCUBIC** 3D printer generates high temperature. Do not reach inside of the printer during operation. Allow time for the printer to cool down after printing. Contact with extruded materials may cause burns. Wait for printed objects to cool before removing them from the build platform.



**ANYCUBIC** 3D printer includes moving parts that can cause injury.



Vapors or fumes may be irritating at operating temperature. Always use the **ANYCUBIC** 3D printer in an open, well ventilated area.



Be cautious when using the scraper. Never direct the scraper towards your hand.



**ANYCUBIC** 3D printer must not be exposed to water or rain.



**ANYCUBIC** 3D printer is designed to be used within ambient temperature ranging 8°C-40°C, and humidity ranging 20%-50%. Working outside those limits may result in low quality printing.



It is recommended to use protection glasses when cleaning/sanding the printed models to avoid small particles contacting eyes.



In case of emergency, immediately turn off the **ANYCUBIC** 3D printer and contact us or consult for professional advice. Never leave the **ANYCUBIC** 3D printer unattended during operation.



# Technical Specification

## Printing

Technology: FDM (Fused Deposition Modeling)  
Build Size: 210mm \* 210mm \* 250 mm  
Print accuracy: 0.1-0.4 mm  
Positioning Accuracy: X/Y 0.0125mm , Z 0.0025mm  
Extruder Quantity: Single  
Nozzle Diameter: 0.4 mm  
Print Speed: 20~60mm/s  
Travel Speed: 60mm/s  
Supported Materials: PLA, ABS, HIPS, Wood

## Temperature

Ambient Operating Temperature : 8°C - 40°C  
Operational Extruder Temperature : max 260°C  
Operational Print Bed Temperature : 100°C

## Software

Slicer Software : Cura  
Software Input Formats : .STL, .OBJ, .AMF  
Software Output Formats : GCODE  
Connectivity : SD card; USB port

## Electrical

Input rating : 110V/220V AC, 50/60Hz

## Physical Dimensions

Printer Dimensions: 410mm \* 475mm \*458mm  
Net Weight: ~10Kg

# Contents

<b>Installation section</b> .....	1	<b>Setup/Print</b> .....	31
S1 Front plate.....	4	1. Level.....	32
S2 Back plate.....	5	2. Driver installation.....	38
S3 Right and left side plate/ bottom frame.....	6	3. Introduction to slicing software.....	42
S4 Y screw rod.....	8	3.1 Cura installation.....	42
S5 Y smooth rod/Belt.....	9	3.2 Manipulate 3D model in Cura.....	46
S6 Print platform.....	11	3.3 Cura settings.....	47
S7 Top frame.....	13	3.4 Print online.....	50
S8 Z motor.....	14	3.5 Print offline.....	51
S9 X/Z smooth rod.....	16	<b>FAQ</b> .....	52
S10 Power supply.....	19	1. Machine.....	53
S11 Y/Z end stop.....	22	2. Printing.....	55
S12 Mainboard.....	25		
S13 Mainboard baffle.....	29		

# Installation section

1. It is suggested to use a flat desktop and place the parts in an orderly manner for quick assembly.
2. Each step has a list of required accessories, assembly diagram and tips. Please read the installation techniques and precautions before assembly.
3. It is suggested to tear off the kraft paper on acrylic plate; Be careful due to the acrylic may has sharp edges; **Excessive force may cause the acrylic to break during assembly.**
4. The color of some parts may be different from the ones in the manual, but the assembly method is the same.
5. Firmware has been uploaded to the motherboard in factory. After completing the assembly, please level the platform and load the filament then you could start the first test print.

# Overview (front)

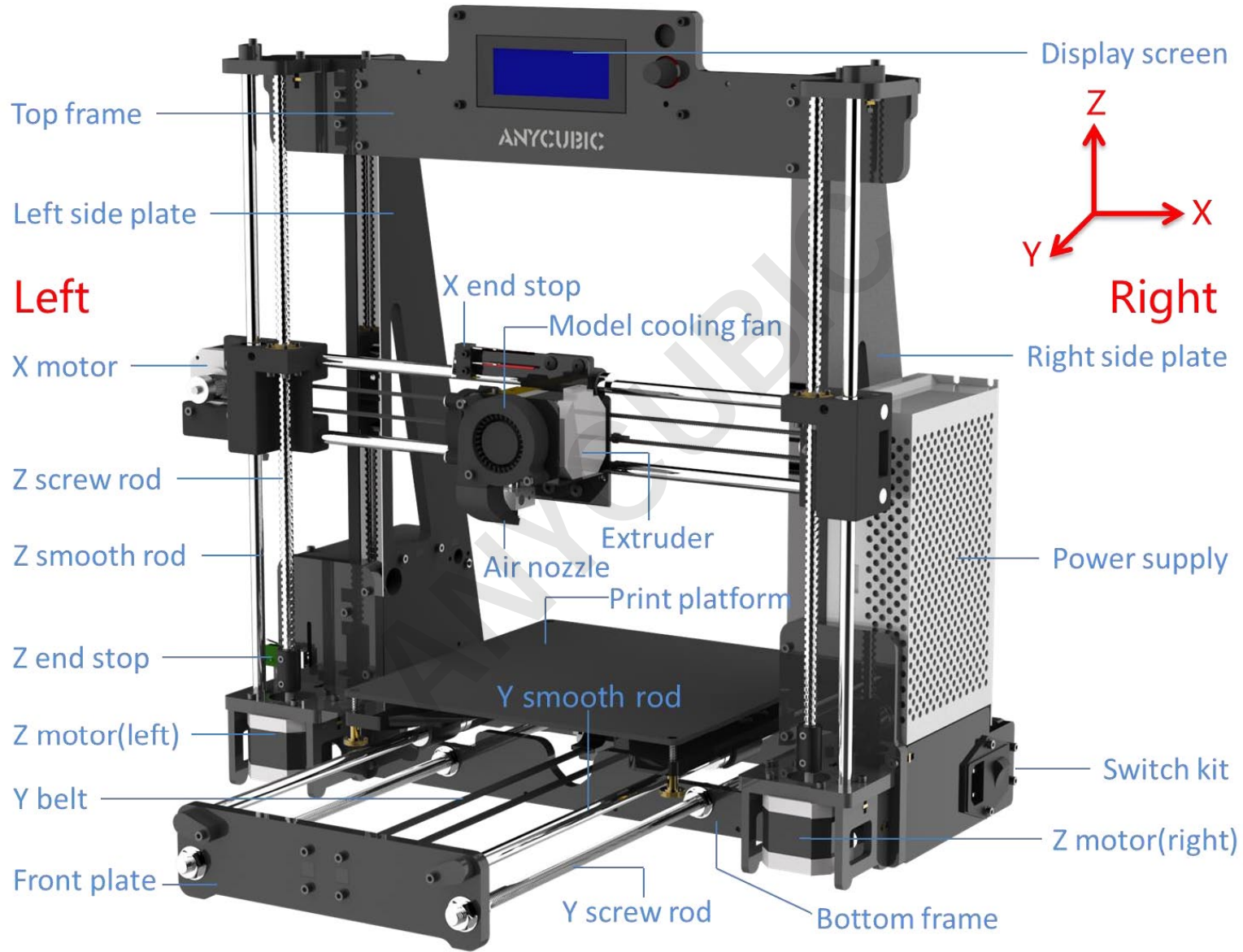

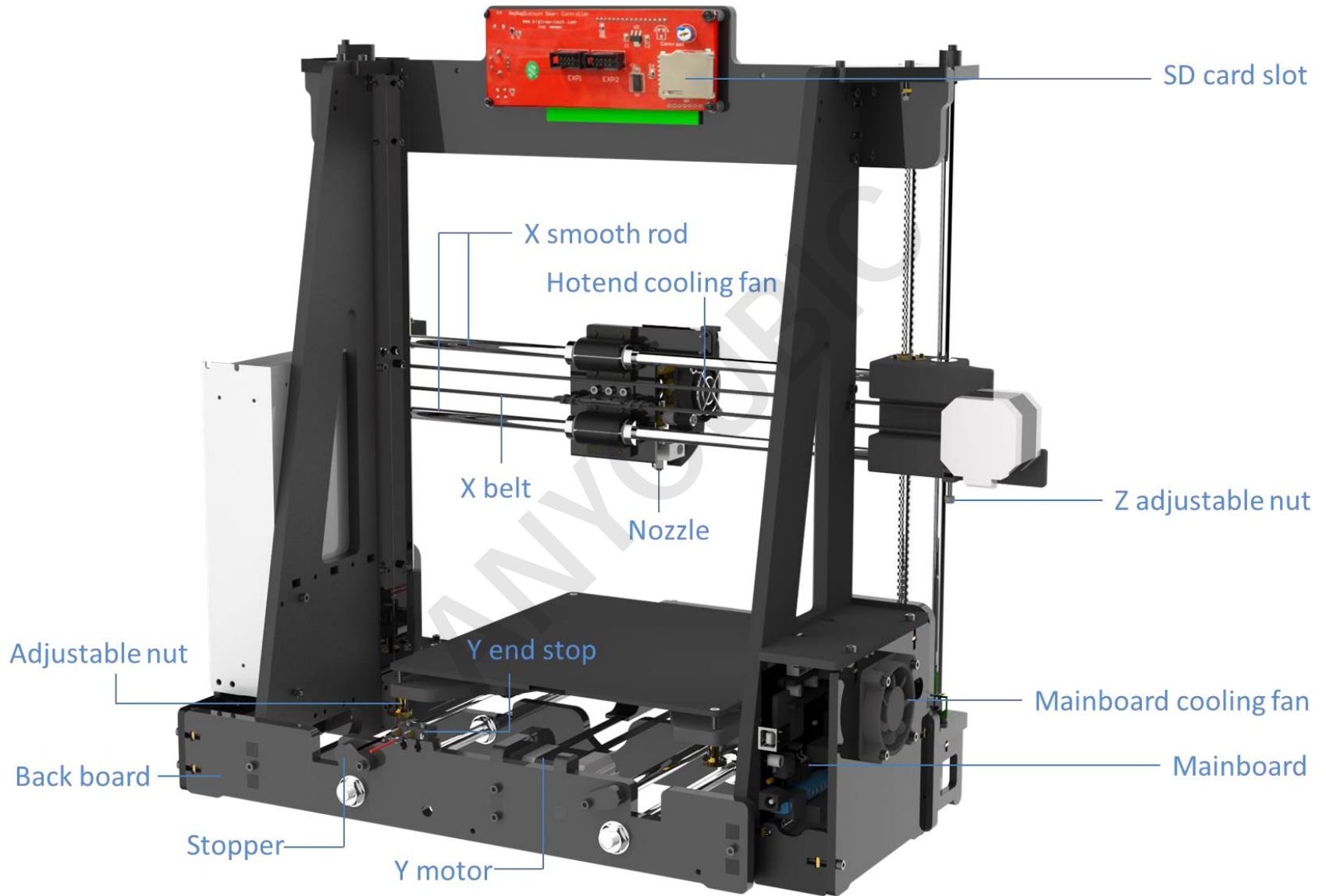

# Overview (rear)



# S1 Front plate

List

		
Front plate 1PCS	Y synchronizing wheel 1PCS	S1 parts pack

Installation diagram

Result



- M3 \* 20 screws do not have to be tightened here.

4

- Use tweezers to hold square nuts and hex nuts for installation, same as below.

## S2 Black plate

List

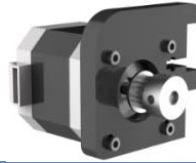

Back plate 1PCS

Y motor ( with wire ) 1PCS

S2 parts pack

Installation diagram



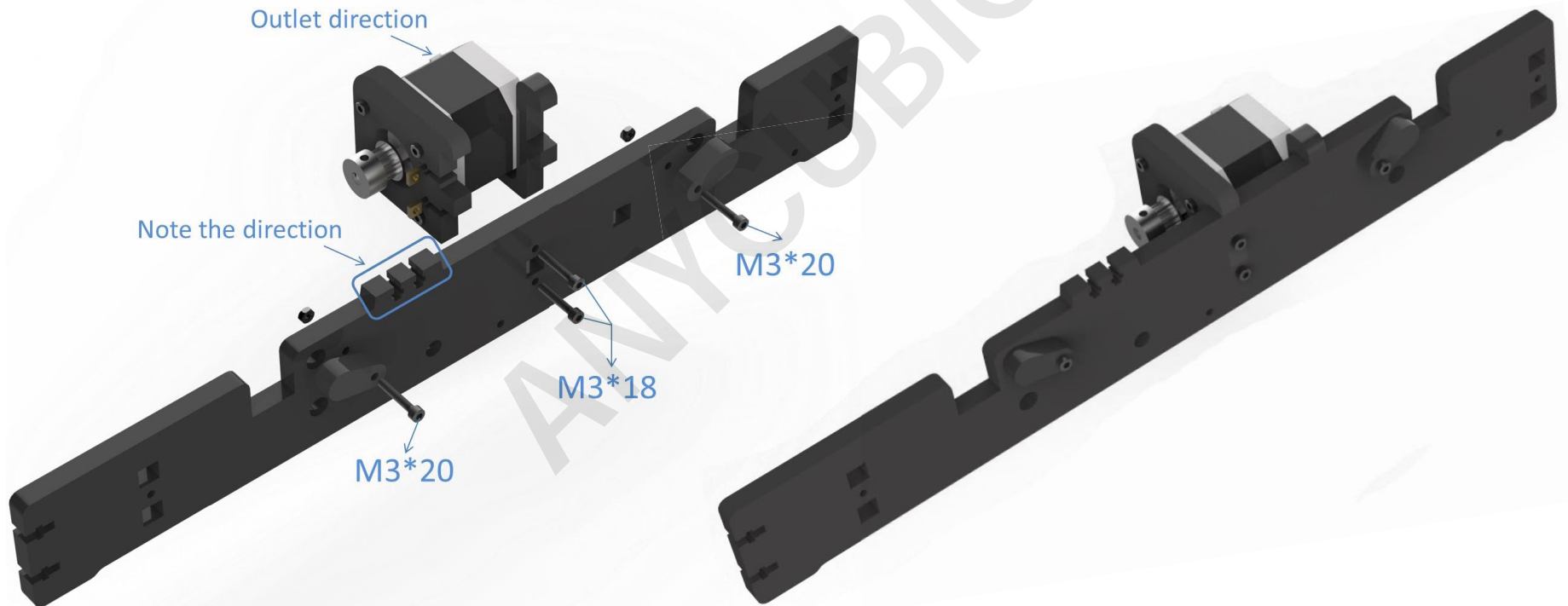

Result



- M3 \* 20 screws do not have to be tightened here.

# S3 Left and right side plate/bottom plate

List

			
Left side plate 1PCS	Right side plate 1PCS	Bottom plate 1PCS	S3 parts pack

Installation diagram①







- The U-shaped hole of the back plate should be on the left, as shown in the installation diagram①.



## S3 Left and right side plate/bottom plate

List

			
Left side plate 1PCS	Right side plate 1PCS	Bottom plate 1PCS	S3 parts pack

Installation diagram②

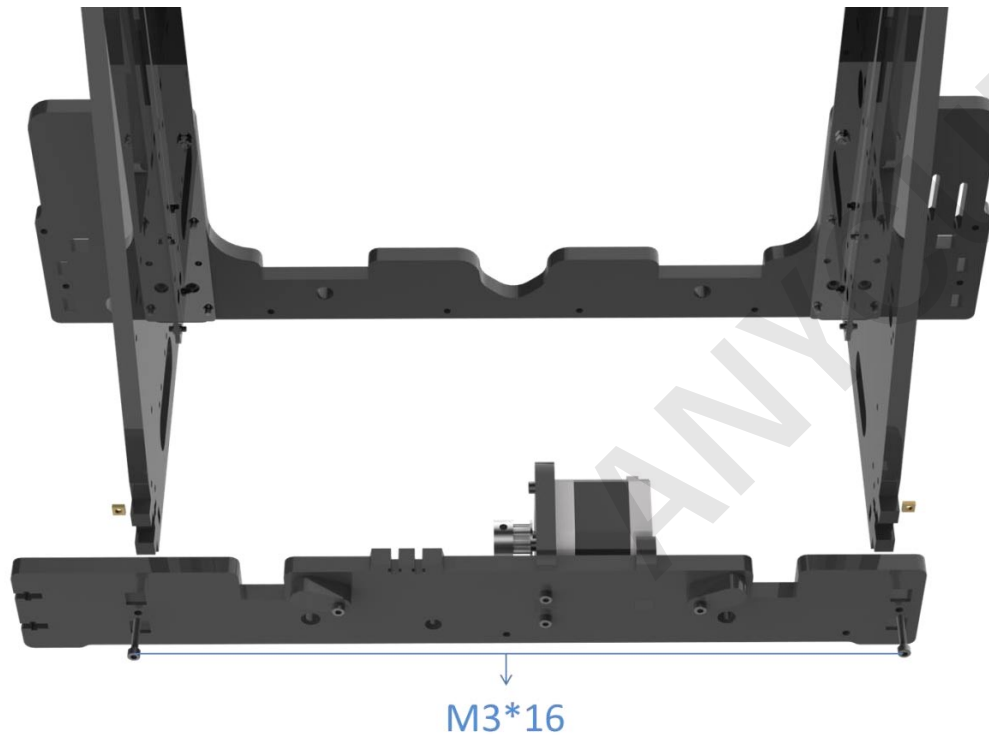

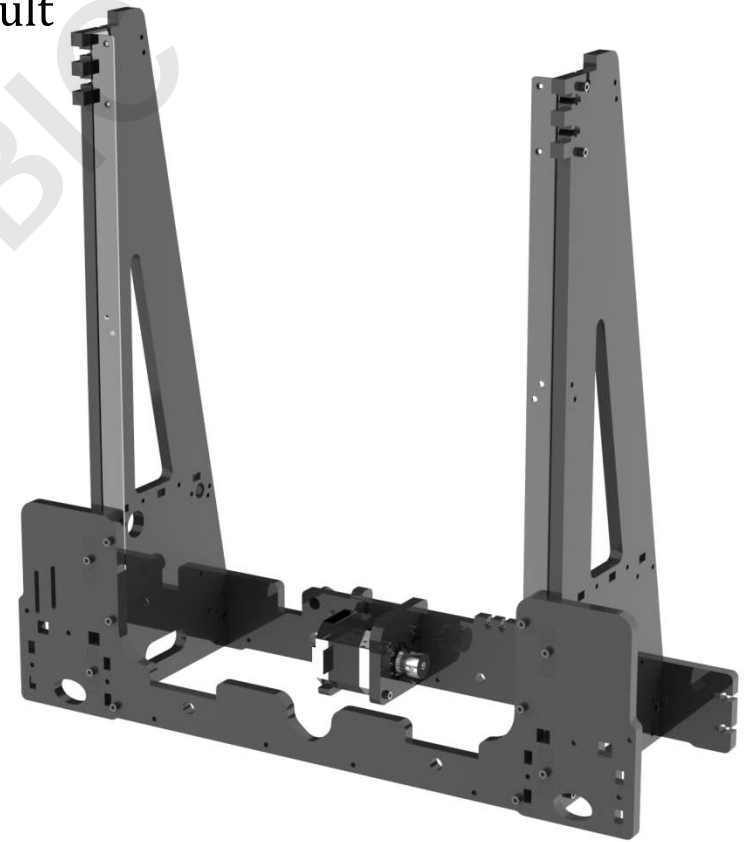

Result



- After assembly, please check whether the left and right side plates are perpendicular to the desktop (or a flat surface), and ensure the whole frame is steady.

# S4 Y screw rod

List

	
Y screw rod ( 410mm ) 2PCS	S4 parts pack

Installation diagram

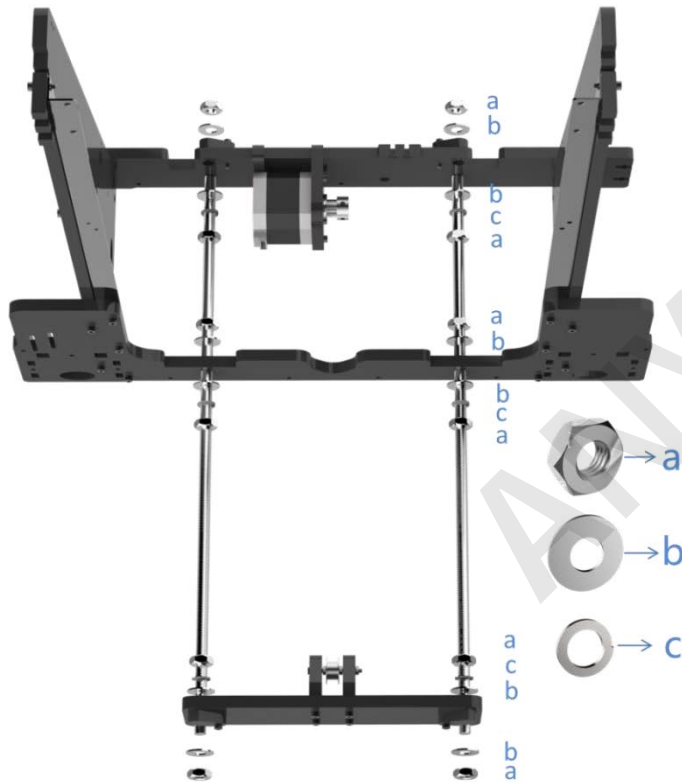

Result

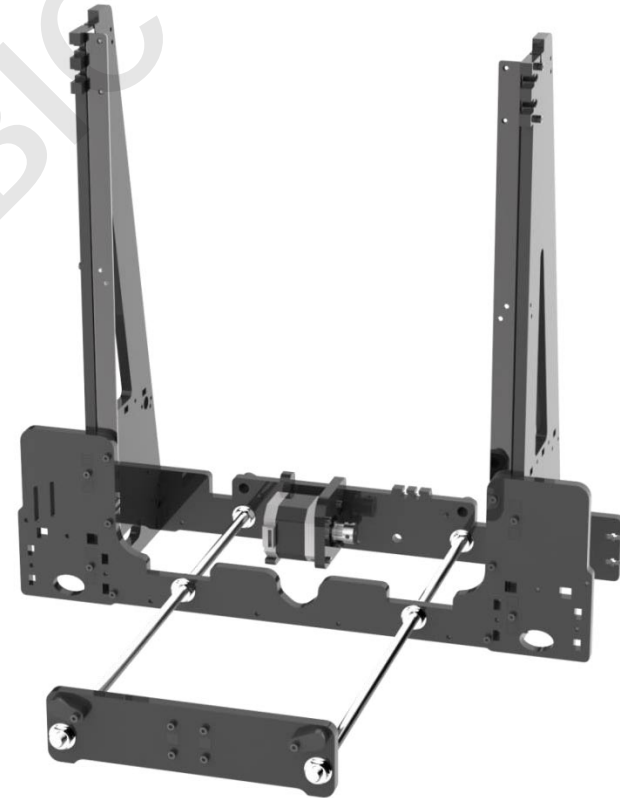



- Do not tighten the screws on the Y screw rods here, because it needs adjustment later to positioning the front and the rear plates.

# S5

## Y smooth rod/belt

List

		
Y smooth rod ( 390mm ) 2PCS	Cable tie 2PCS	S5 parts pack

Installation diagram①

Left

The Y smooth rods are longer than other two smooth rods in the package.

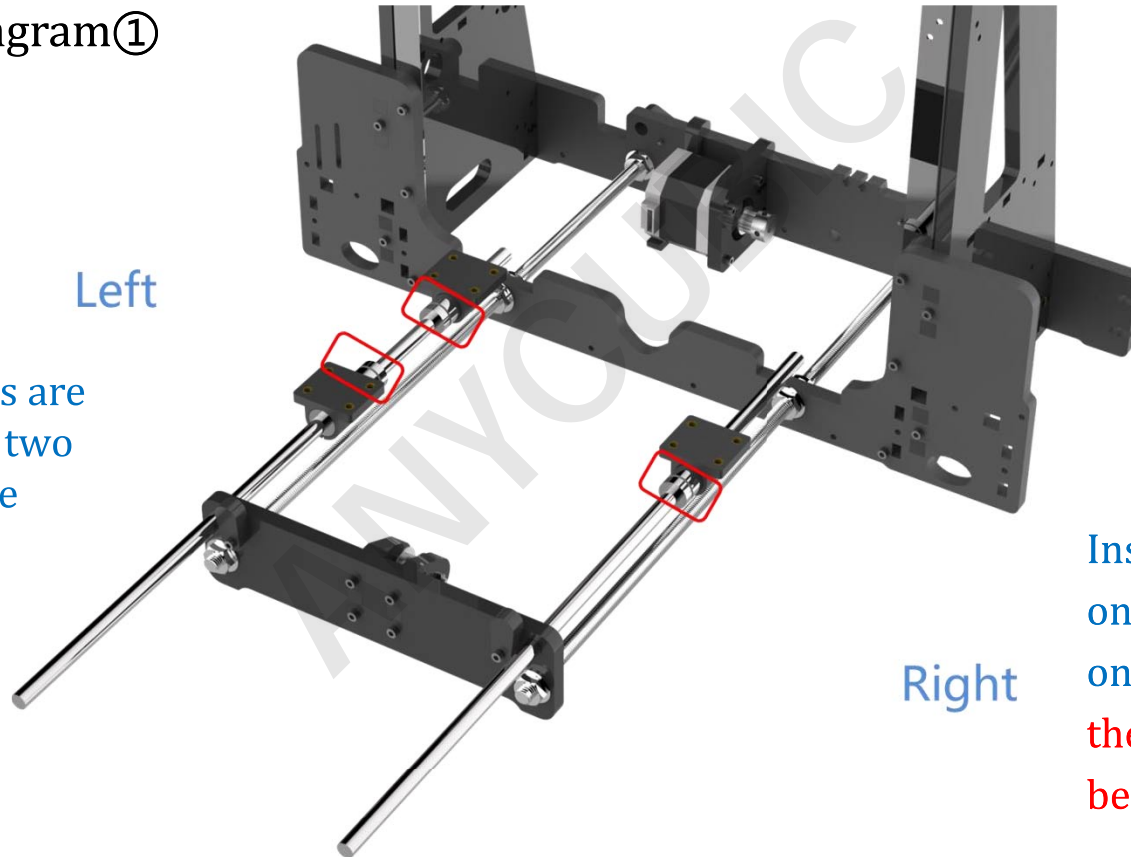



Right

Install two linear bearings on the left smooth rod and one on the right side, **note the directions of the bearings .**

- Tighten the M3 \* 20 screws that fix the stoppers on front and back plate, in order to block the Y smooth rods.
- Finally, all parts on the Y-axis screw rods can be tightened with a wrench. Do not over tight the parts, which may make the frame out of shape. The Y smooth rods should be fixed in place after tightening.

List

		
Y smooth rod ( 390mm ) 2PCS	Cable tie 2PCS	S5 parts pack

Installation diagram②



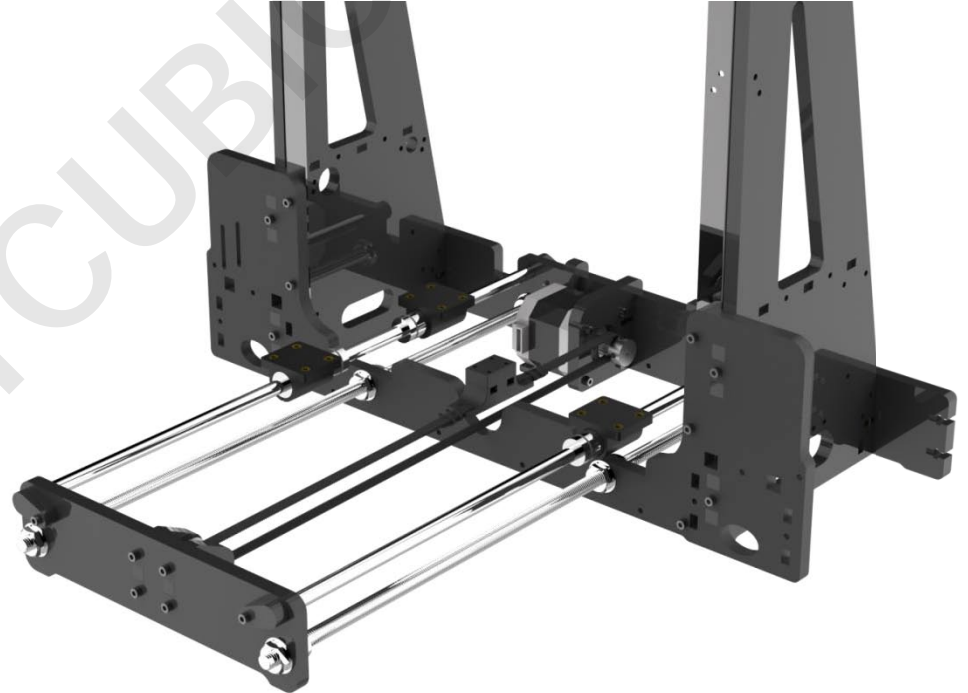

Result



- Cut off the redundant belt, otherwise it will affect the maximum travel distance of Y axis.
- Keep the belt as tight as possible, for better printing accuracy. You may loosen and then tighten the M3\*18 screws that fix the Y synchronizing wheel on the front plate when install the belt.

## S6 Print platform

List

		
Platform support plate 1PCS	Print platform 1PCS	S6 parts pack

Installation diagram①

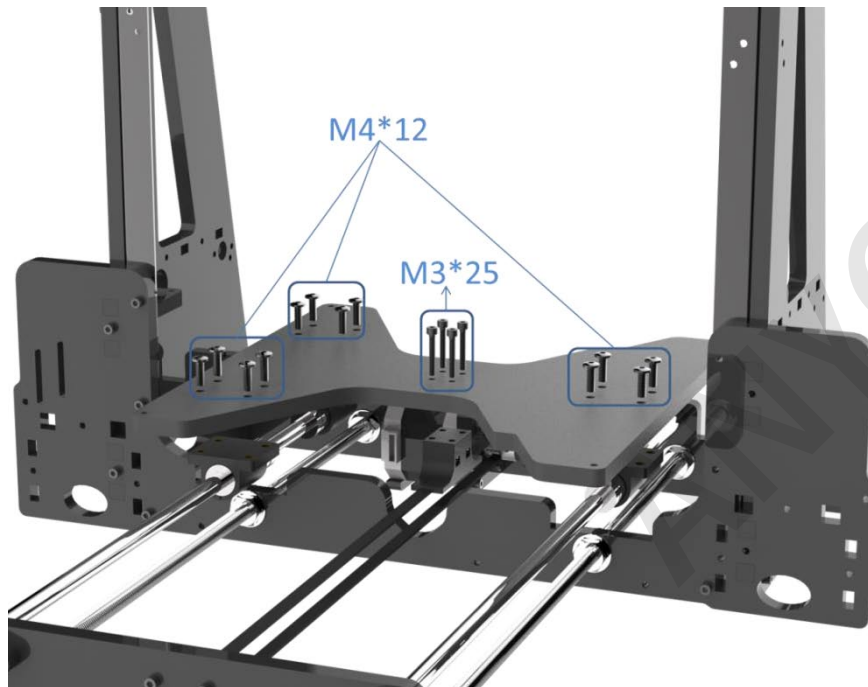

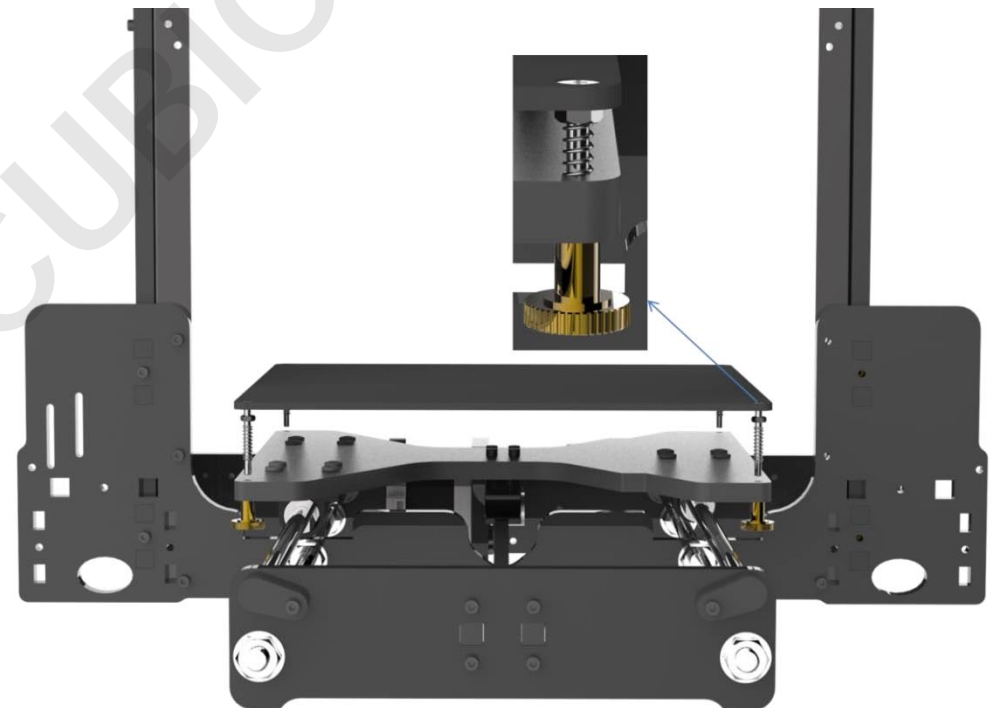

Installation diagram②



- It is suggest to slide the support plate back and forth on the smooth rods to ensure there is no obvious abnormal friction, and then tighten the 12 pieces of M4 \* 12 and M3 \* 25 screws .

# S6 Print platform

List

		
Platform support plate 1PCS	Print platform 1PCS	S6 parts pack

Installation diagram③

Result

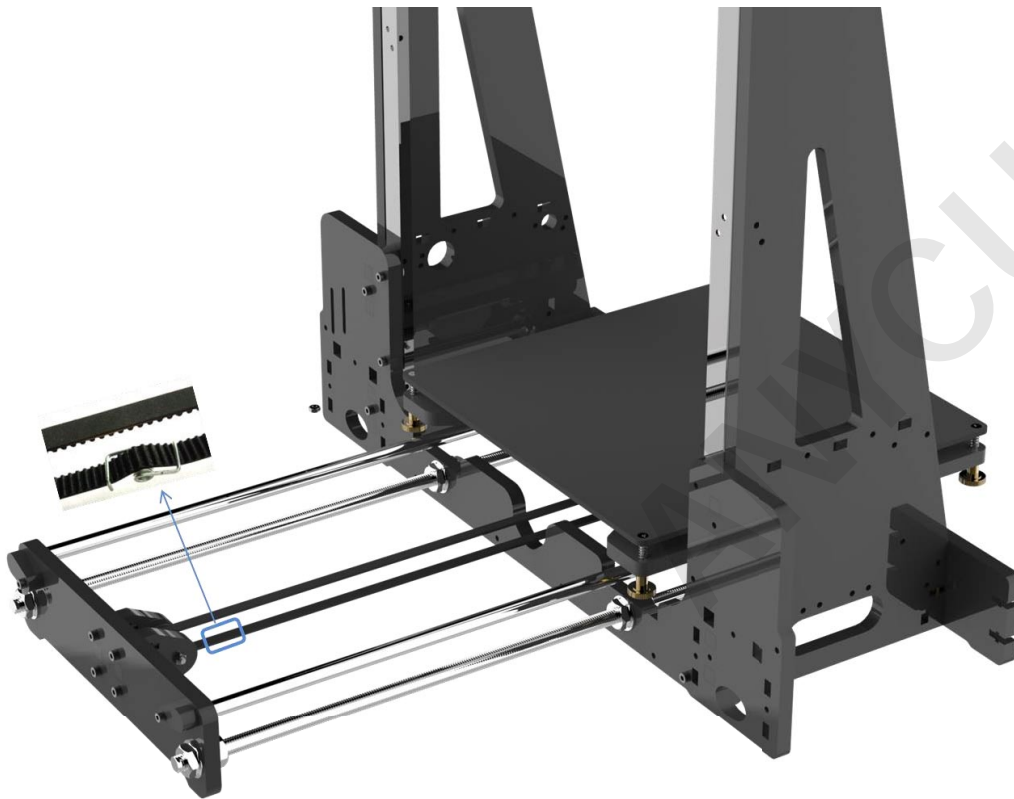

- To get a better tightness of the Y belt, it is suggested to move the platform to the rear, and use the plier to install the belt tension spring about 2cm away from the Y synchronizing wheel.

# S7 Top frame

List



Top frame 1PCS

S7 parts pack

Installation diagram

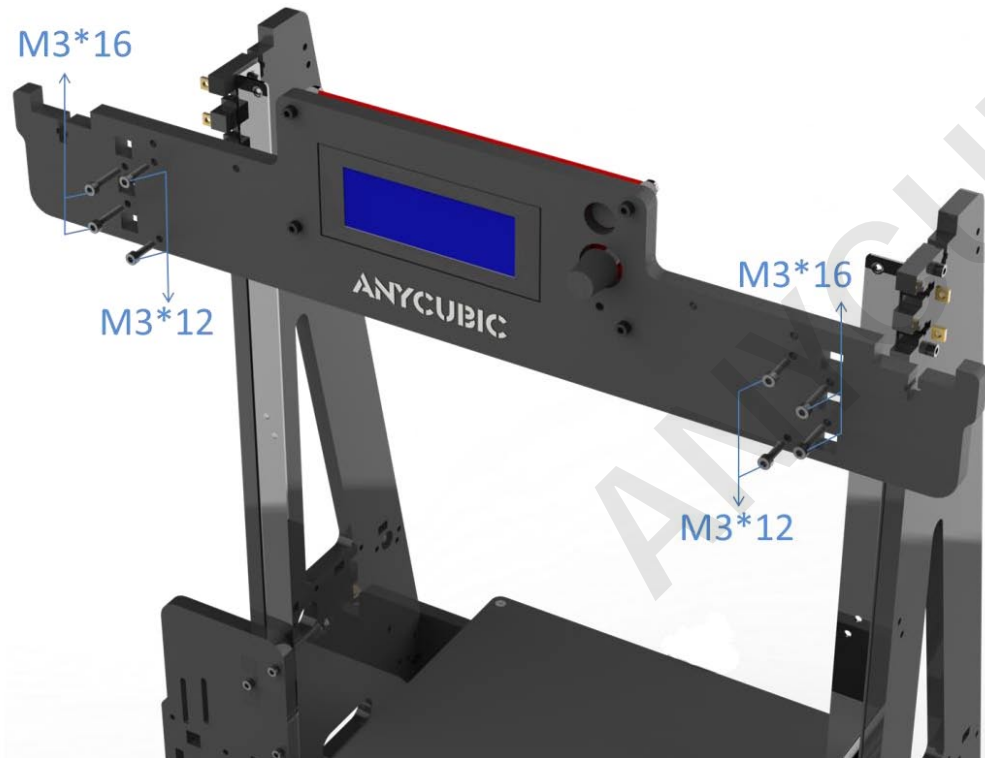



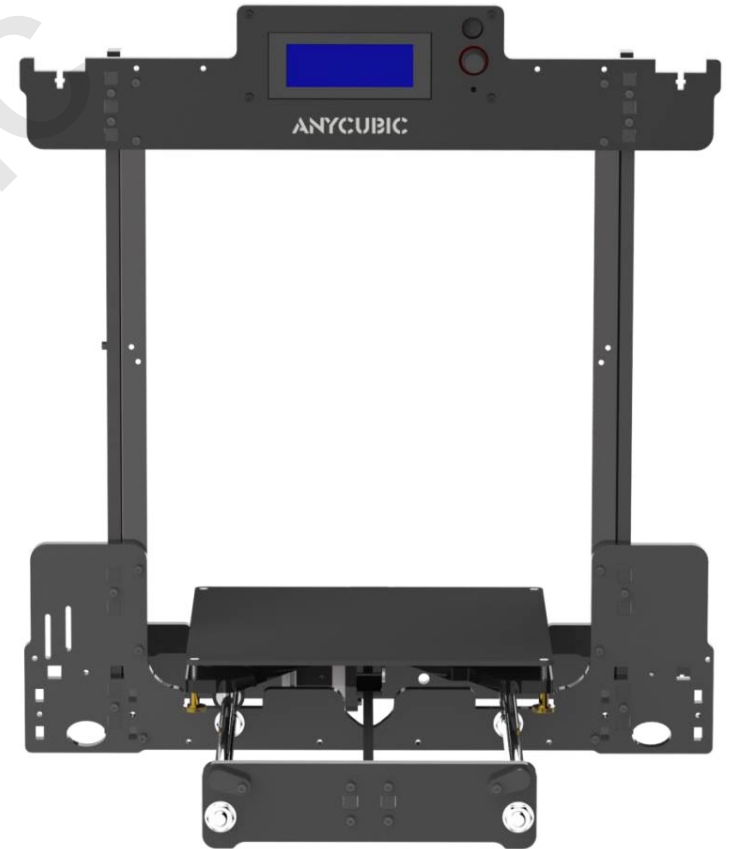

Result



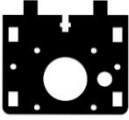

List

				
Z motor mounting plate 2PCS	Z motor support plate 4PCS	Z motor ( left , short wire ) 1PCS	Z motor ( right , long wire ) 1PCS	S8 parts pack

Installation diagram①

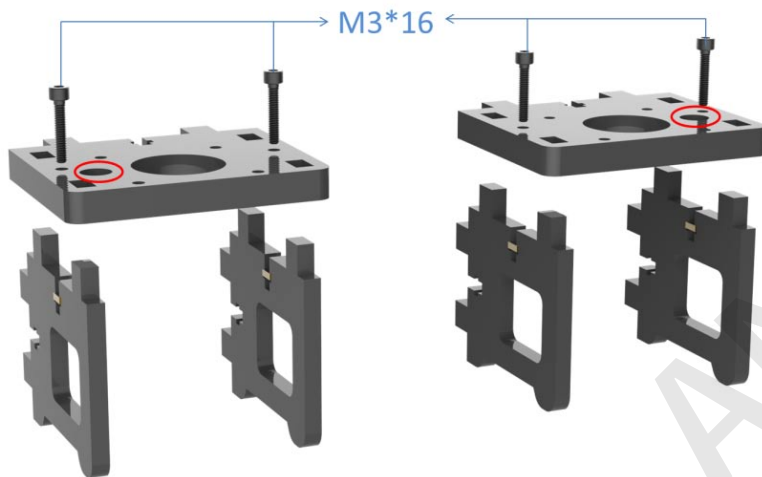

Installation diagram②

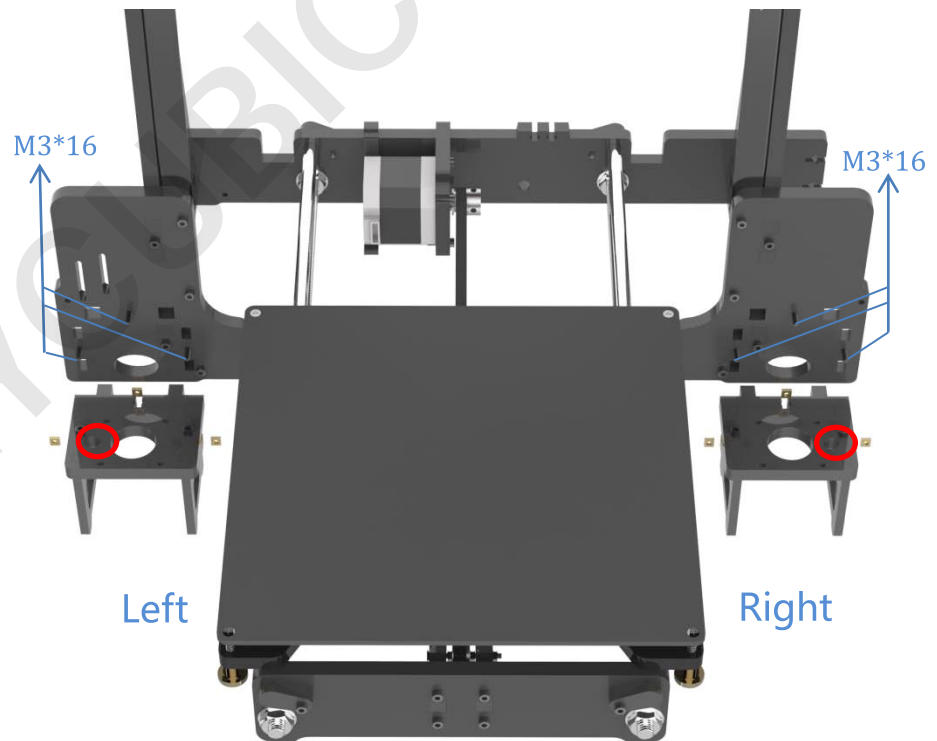





- Notice the direction: the two small round holes on the Z motor mounting plates should be at the outside.
- In the installation diagram② , for easy installation of the M3 \* 16 screws, the platform must be moved to the front.

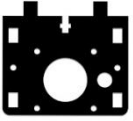

# S8 Z motor

List

				
Z motor mounting plate 2PCS	Z motor support plate 4PCS	Z motor ( left , line shot ) 1PCS	Z motor ( right , line long ) 1PCS	S8 parts pack

Installation diagram③

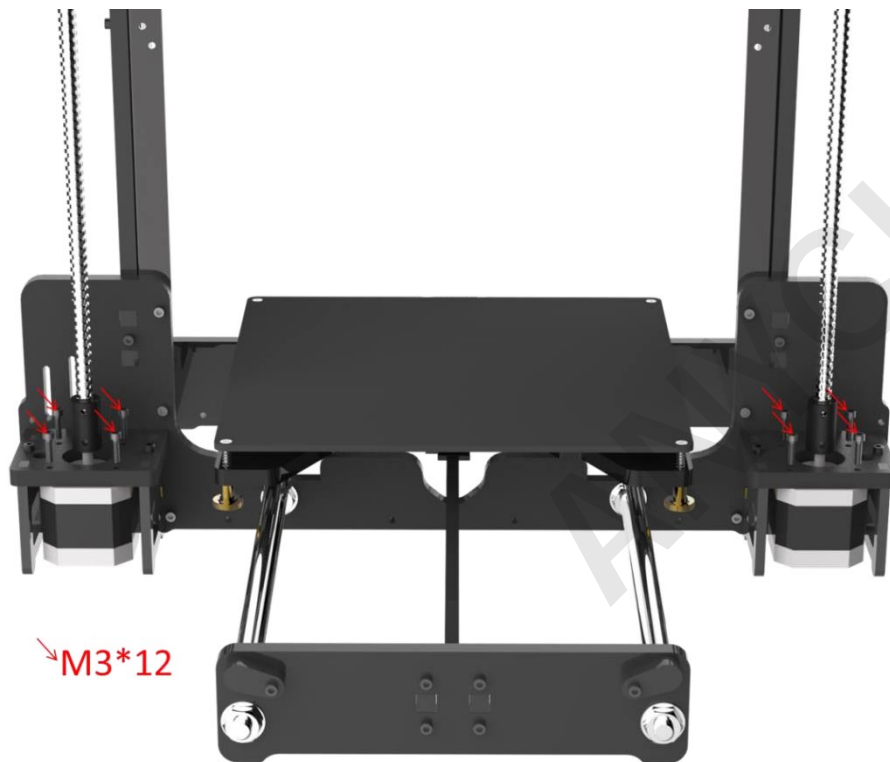





Result



- Make sure that the Z motors is perpendicular to the desktop.

## S9 X/Z smooth rod

List

			
X axis 1PCS	Z smooth rod ( 380.5mm ) 2PCS	Top mounting plate 2PCS	S9 parts pack

Installation diagram①

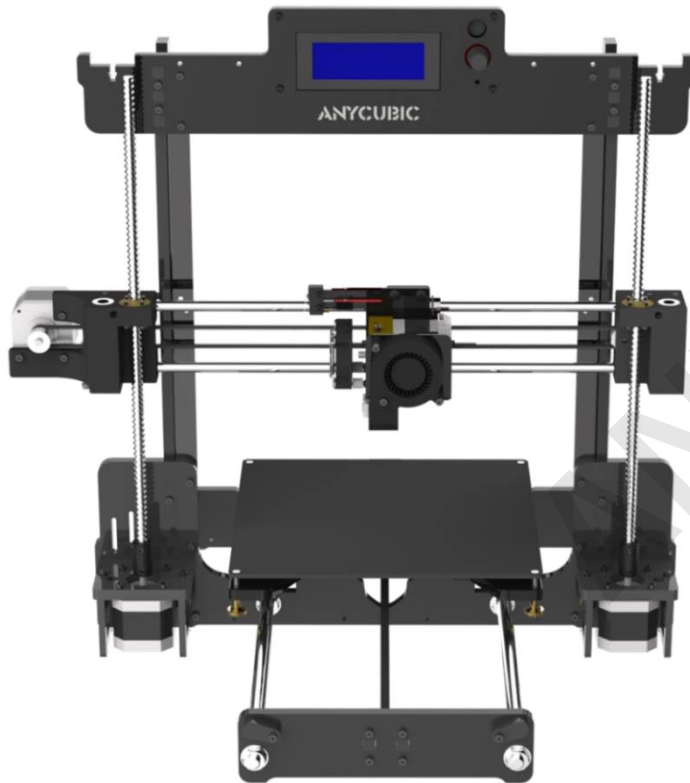



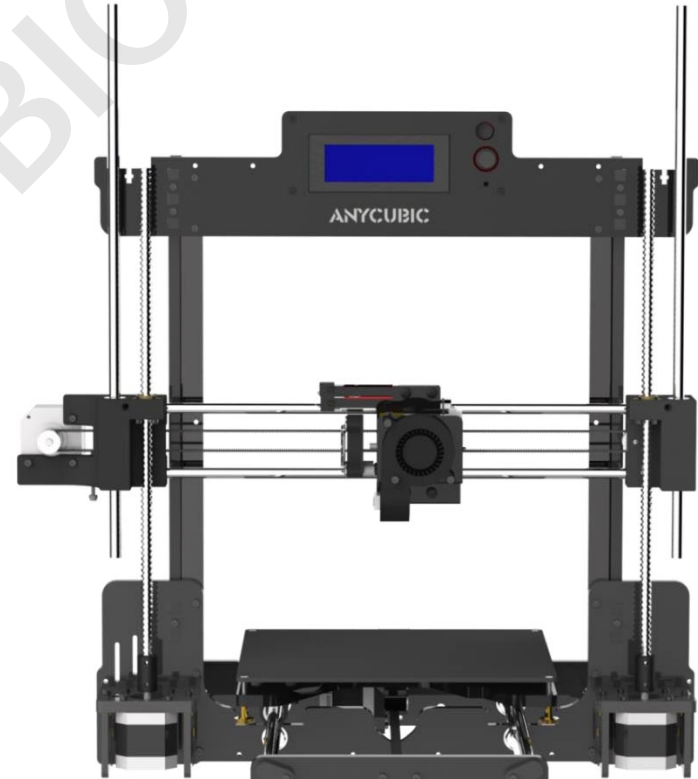

Installation diagram②



- As in the installation diagram ①, simultaneously rotate screw rods so that the X axis could move down.

## S9 X/Z smooth rod

List

			
X axis 1PCS	Z smooth rod ( 380.5mm ) 2PCS	Top mounting plate 2PCS	S9 parts pack



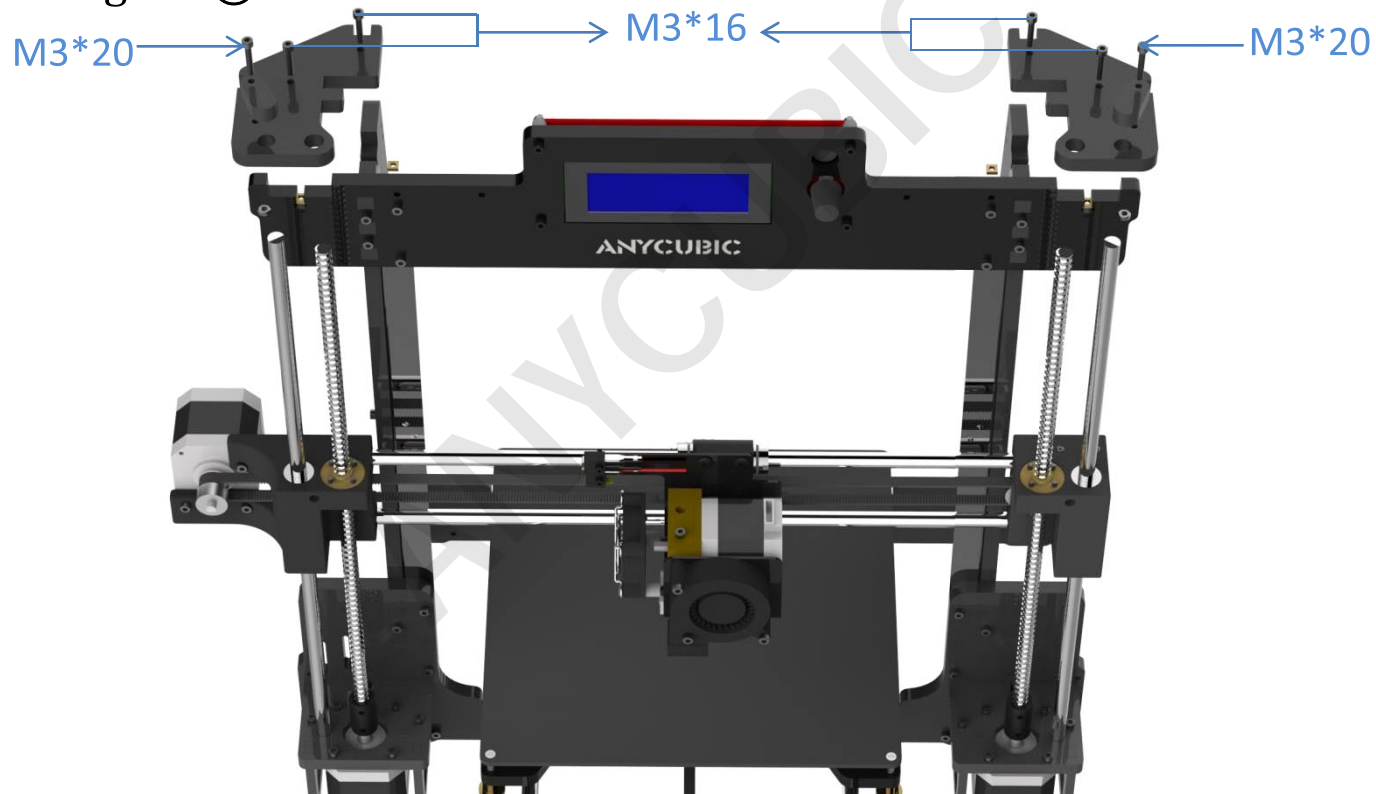

Installation diagram③

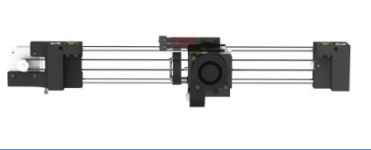

- Make sure that there is no obvious resistance when twisting the Z screw rods and sliding extruder.

## S9 X/Z smooth rod

List

			
X axis 1PCS	Z smooth rod ( 380.5mm ) 2PCS	Top mounting plate 2PCS	S9 parts pack

Installation diagram④

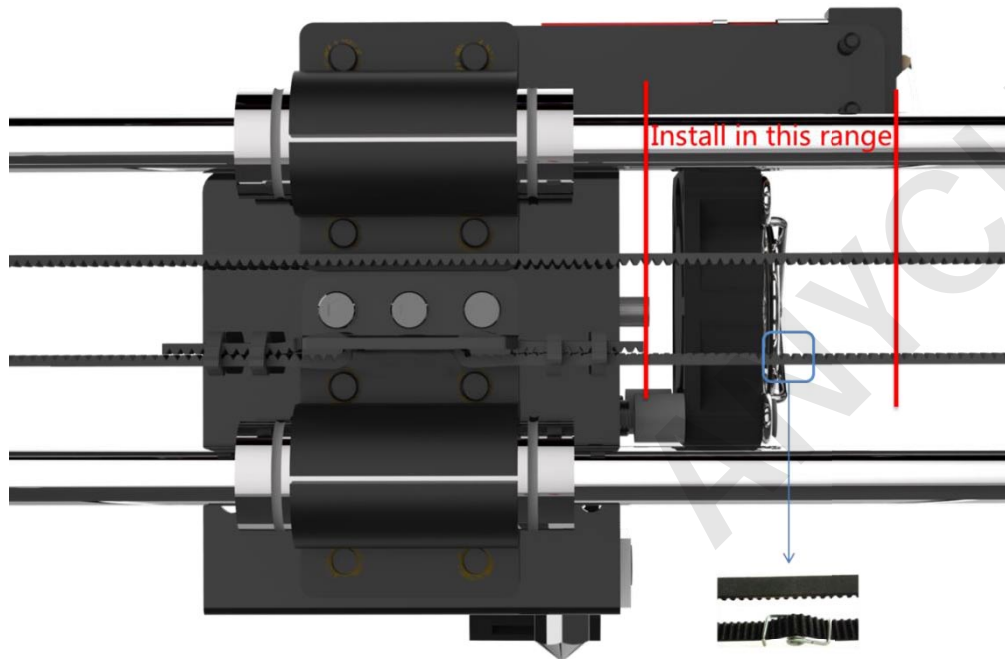

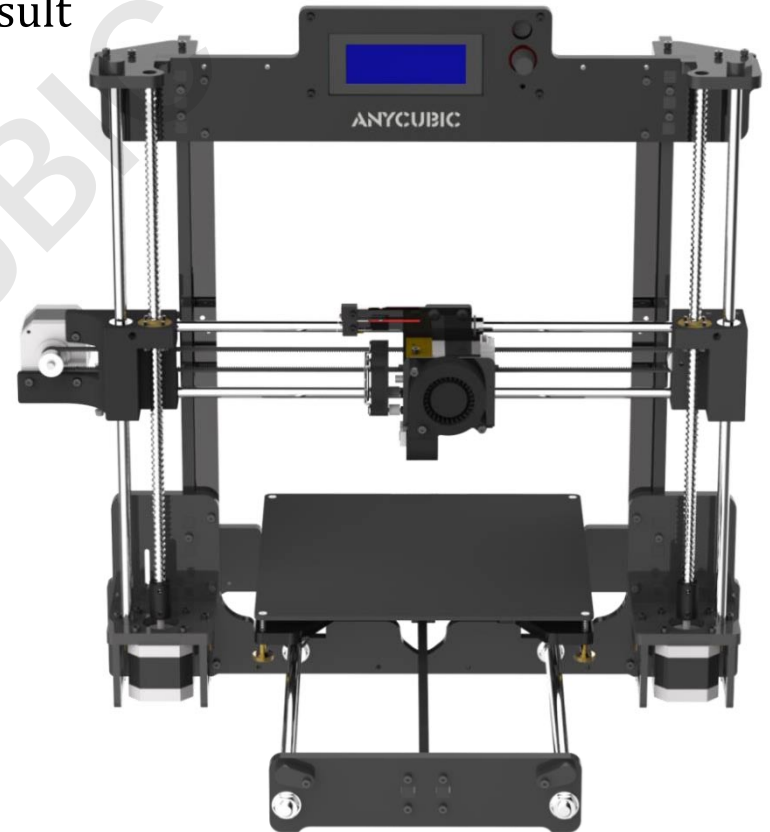

Result



- If the X belt is too loose, you can use the pliers to install the belt tension spring as shown in diagram ④.

# S10 Power supply

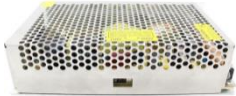
List

				
Power supply 1PCS	Switch fixing plate 1PCS	Switch kit ( with line ) 1PCS	12V power line 1PCS	S10 parts pack

Installation diagram①



Select the correct voltage mode according to your local voltage ratings (110V/220V). The switch is inside the power supply and 220V is default. Allan keys can be used to move this switch.



Installation diagram②

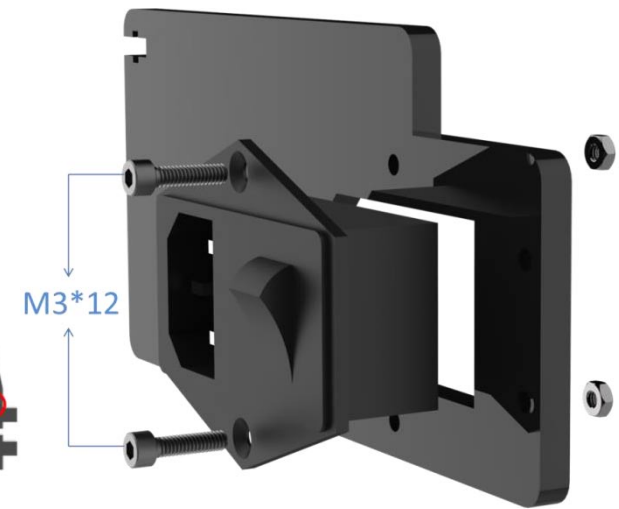
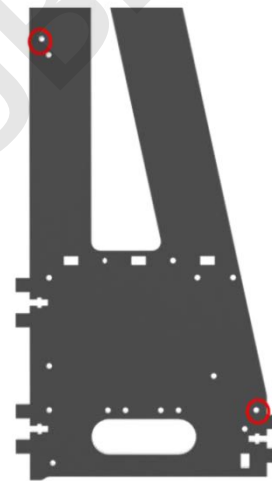



- Install the power supply on the right plate, the fix position is shown in the red circle.



# S10 Power supply

List

				
Power supply 1PCS	Switch fixing plate 1PCS	Switch kit ( with line ) 1PCS	12V power line 1PCS	S10 parts pack



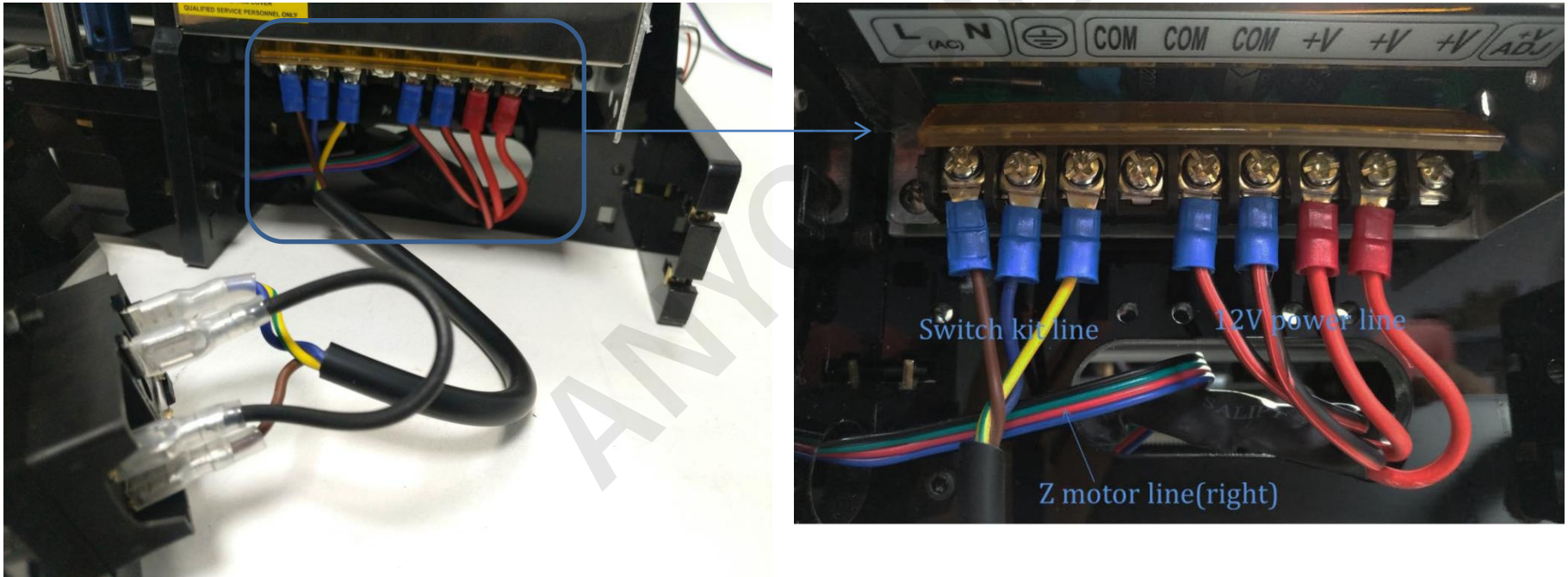

Installation diagram③

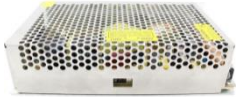

- Connect the switch kit line and the 12V power line to the power supply, pass the other end of the 12V power line and Z motor line through the hole to be connected onto mainboard.

# S10 Power supply

List

				
Power supply 1PCS	Switch fixing plate 1PCS	Switch kit ( with line ) 1PCS	12V power line 1PCS	S10 parts pack

Installation diagram④

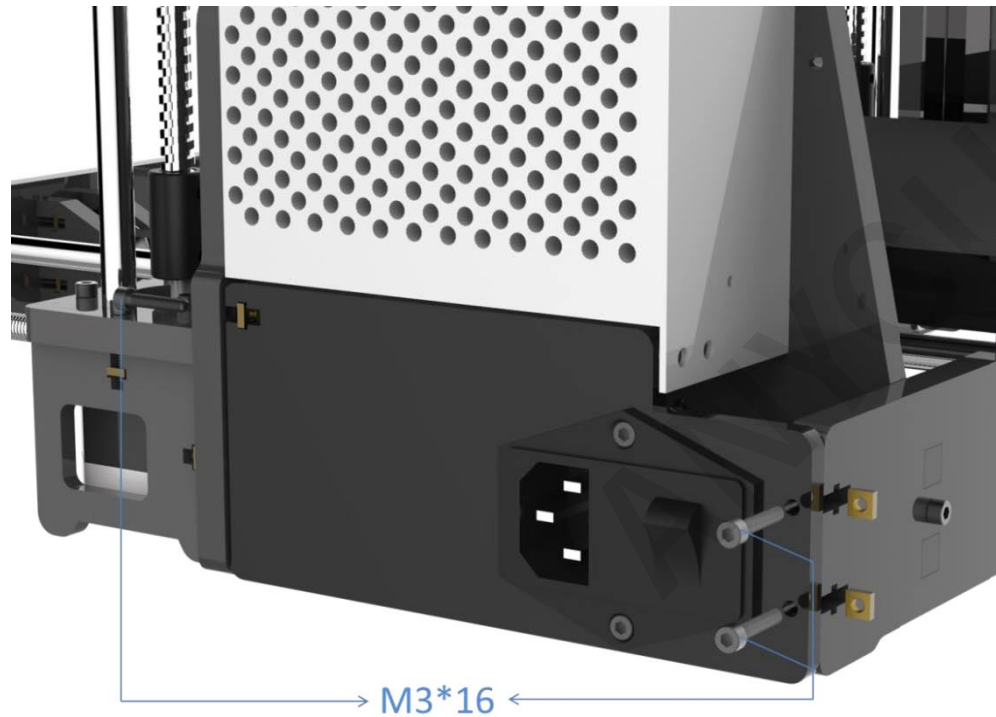

Result

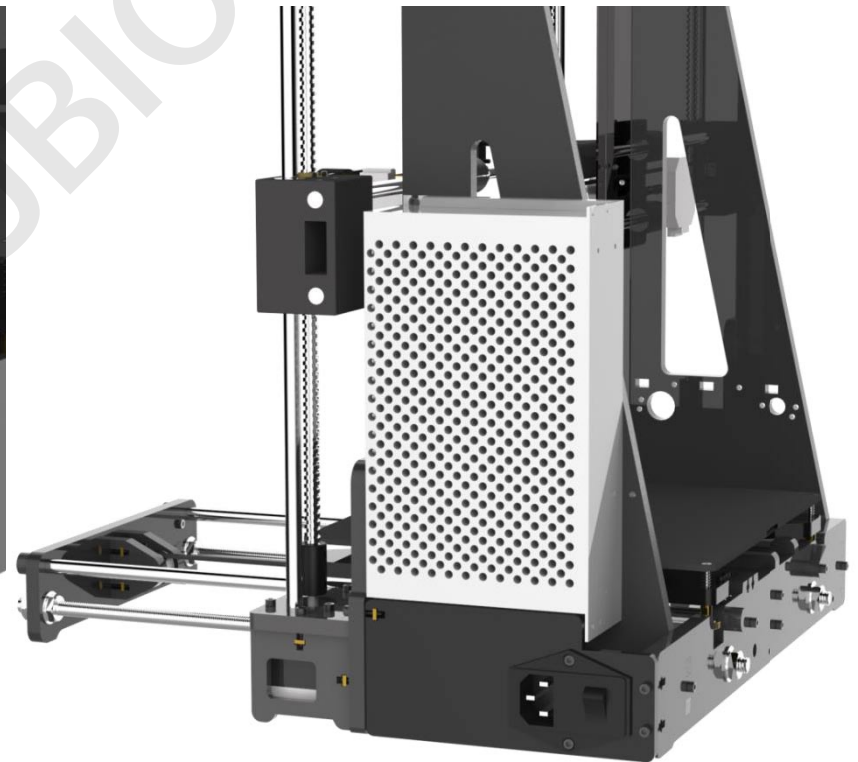

# S11 Y/Z end stop

List



Y end stop 1PCS

Z end stop 1PCS

S11 parts pack

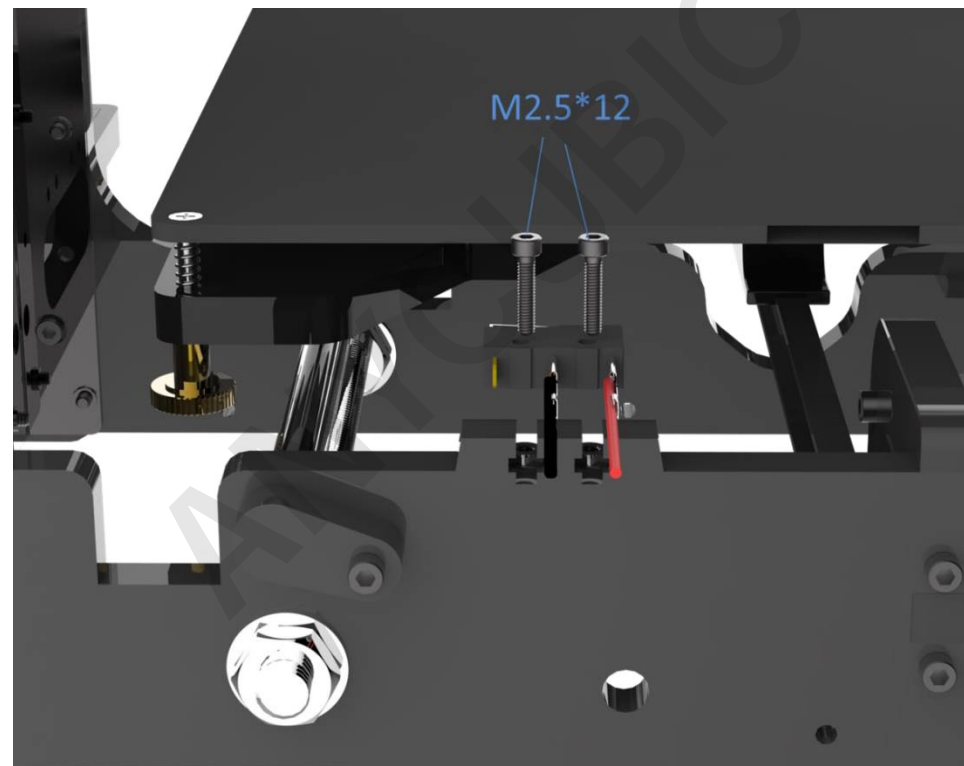

Installation diagram①





# S11 Y/Z end stop

List

		
Y end stop 1PCS	Z end stop 1PCS	S11 parts pack

## Installation diagram②

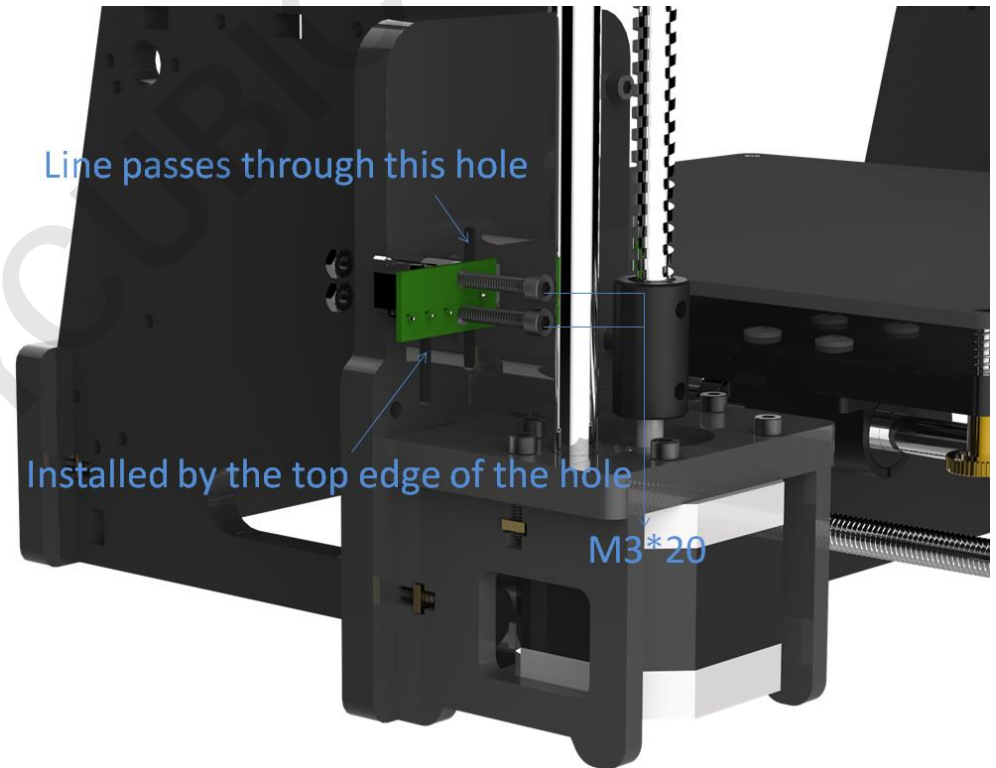
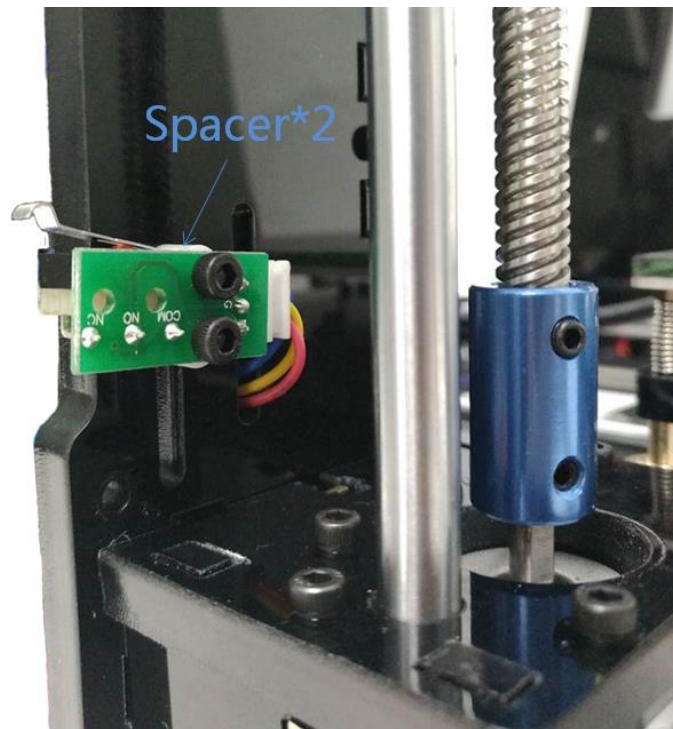

- Two spacers are inserted between the Z end stop and the bottom frame.

# S11 Y/Z end stop

List



Y end stop 1PCS



Z end stop 1PCS





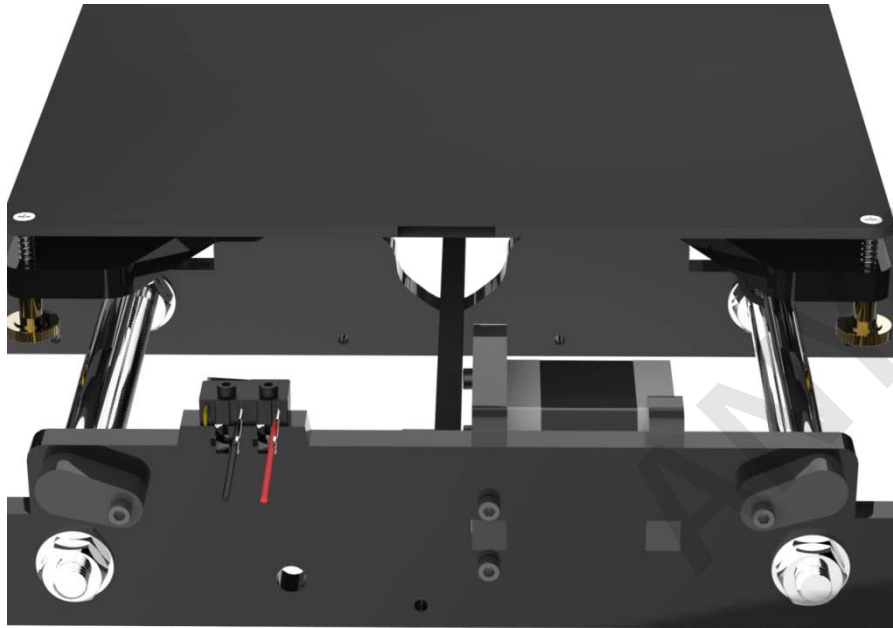

S11 parts pack

Result

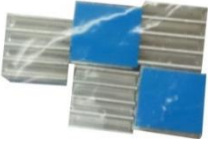

# S12 Mainboard

List

			
Mainboard 1PCS	Cable tie a few	Heat sink 5PCS	S12 parts pack

Installation diagram①

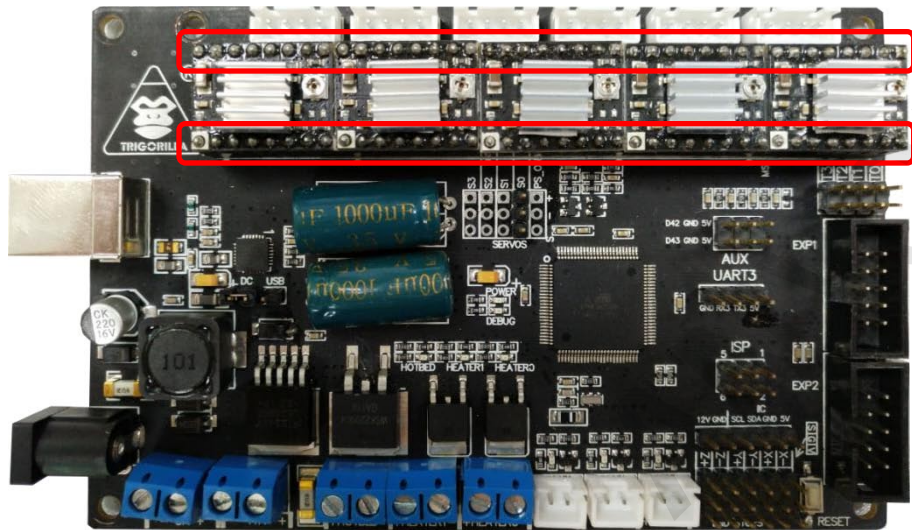



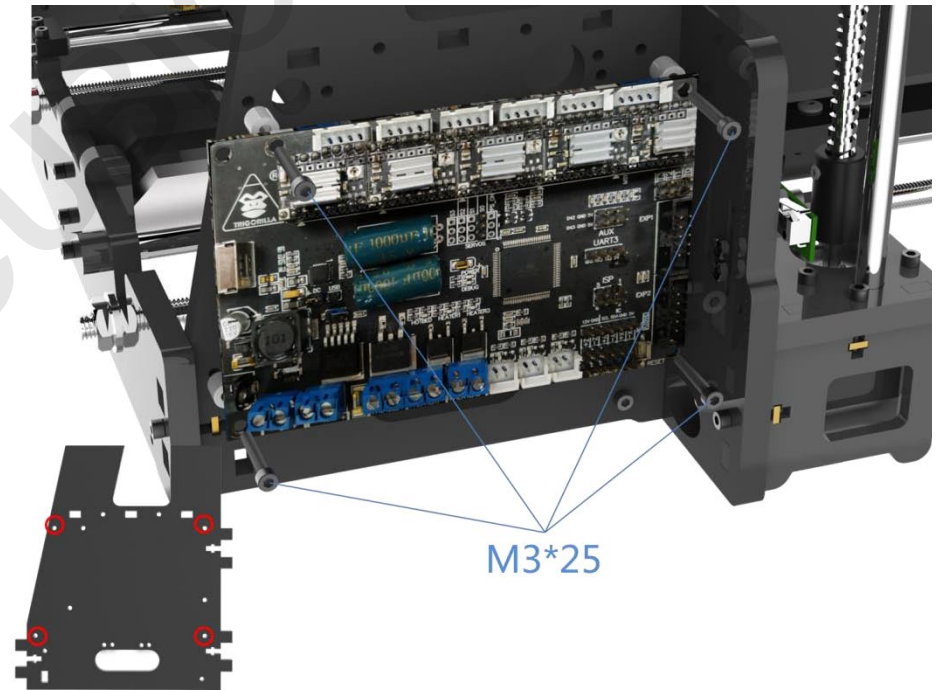

Installation diagram②



- Do not let the heat sink touch any of the pins on the A4988 driver (indicated by read square).

# S12 Mainboard

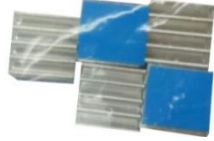
List

			
Mainboard 1PCS	Cable tie a few	Heat sink 5PCS	S12 parts pack

## Installation diagram③

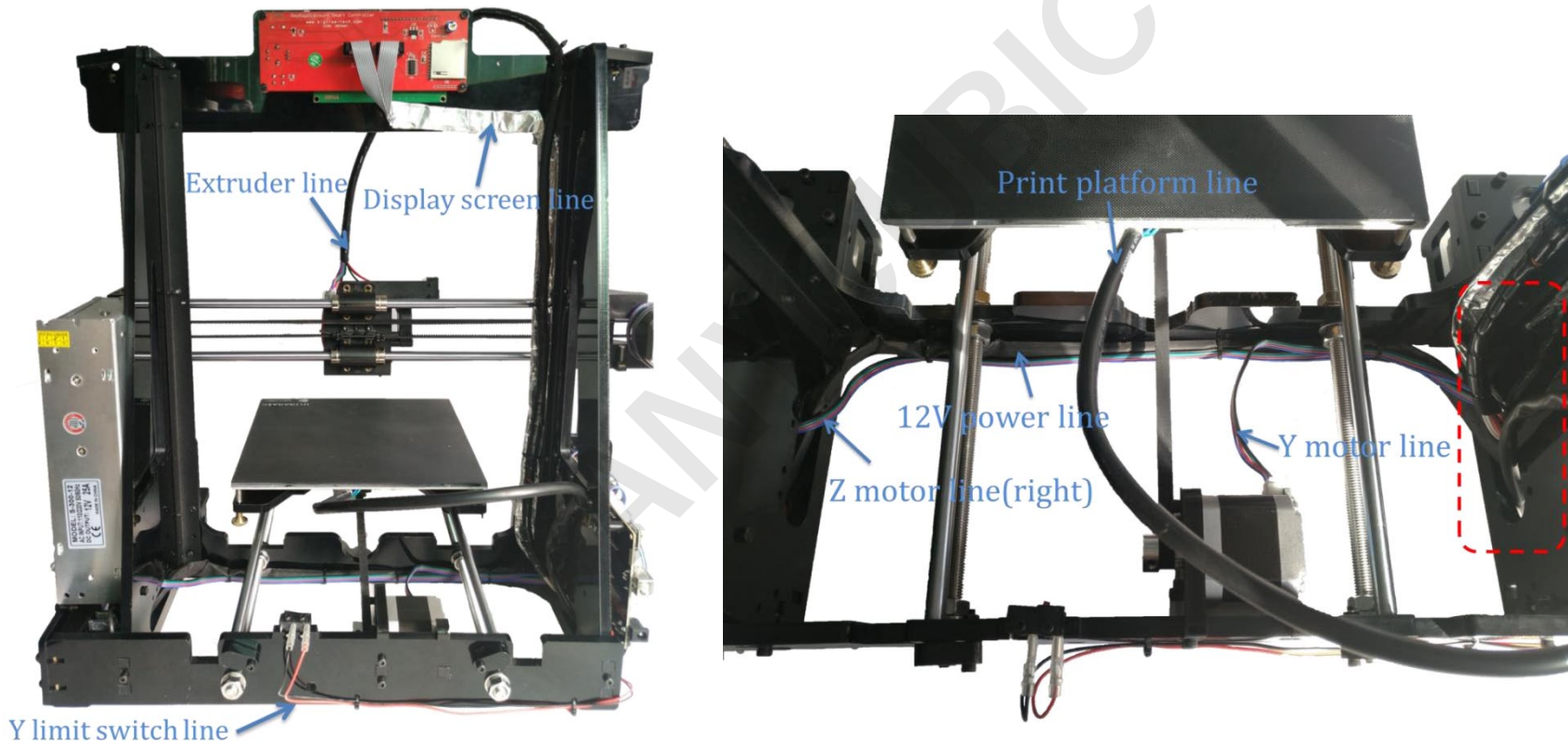

- Fix those wires with cable ties and pass through the left side plate. Insert the wire into the mainboard according to the wiring diagram (next page).





# S12

# Mainboard board

List



Mainboard 1PCS



Cable tie a few

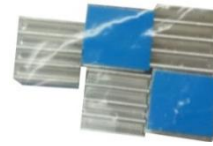

Heat sink 5PCS





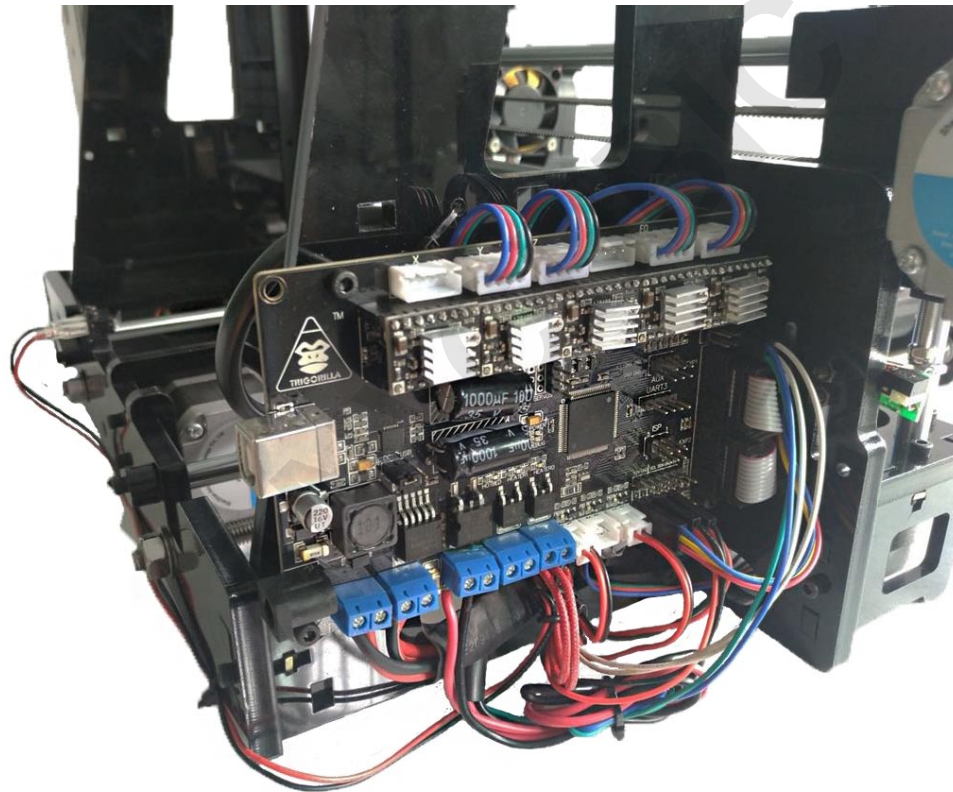

S12 parts pack

Result

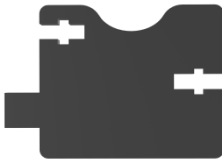

# S13 Mainboard baffle

List

			
Fan fixing plate 1PCS	Top baffle 1PCS	Side baffle 1PCS	S13 parts pack

Installation diagram①

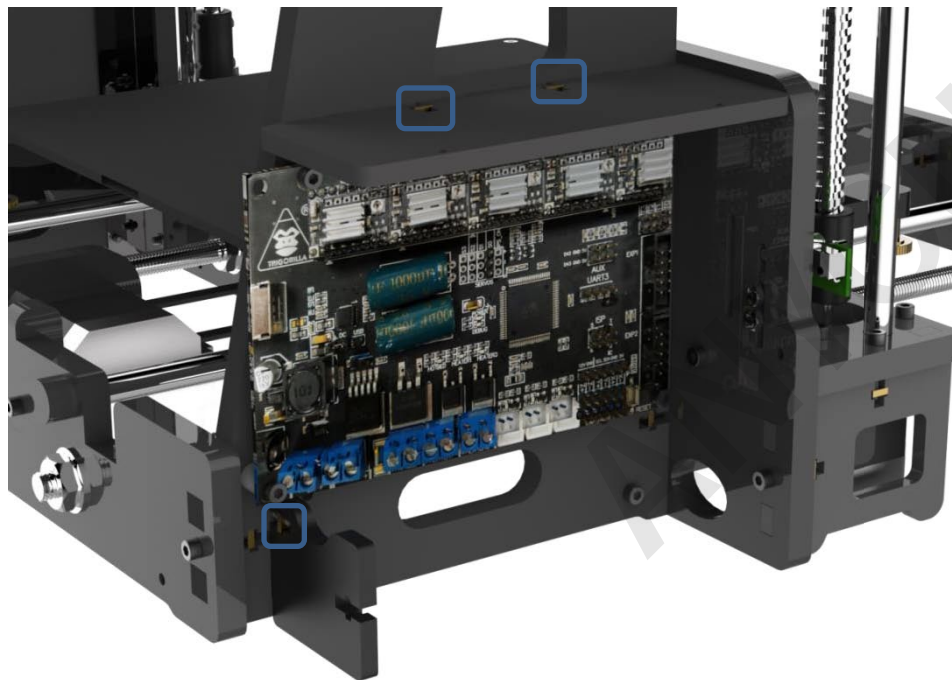

Installation diagram②







- Use tweezers to hold the square nuts when tightening M3\*16 screws, same as below.

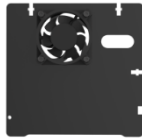

# S13 Mainboard baffle

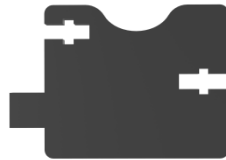
List

			
Fan fixing plate 1PCS	Top baffle 1PCS	Side baffle 1PCS	S13 parts pack

Installation diagram③

Result

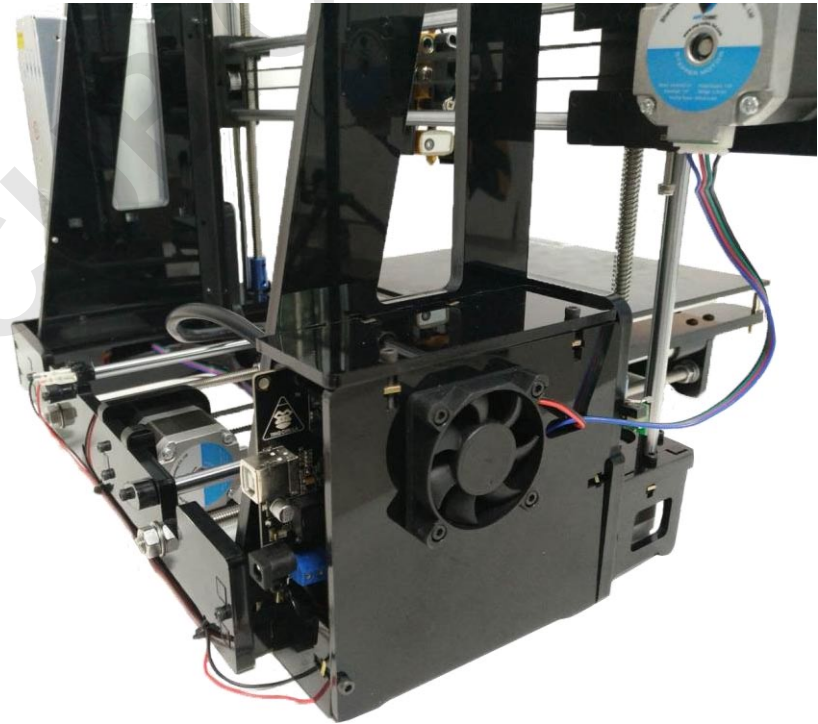
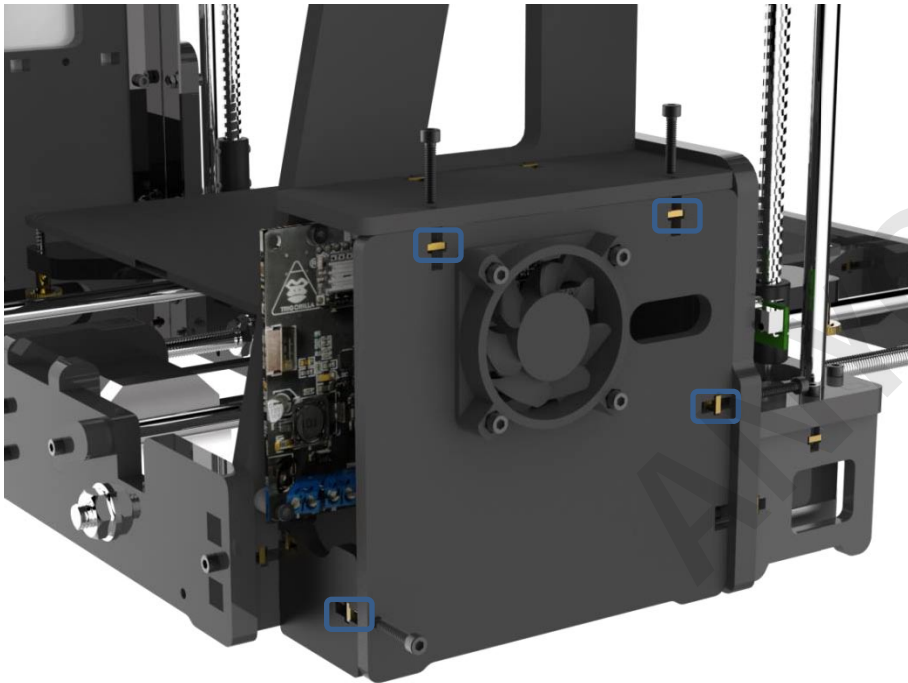

- Till now, the assembly has been finished. Please thoroughly check the whole mechanical parts for any misconnection, wrong assembly, wire interference, especially for the X/Y/Z axis.



# Setup/Print

- Level
- Driver installation
- Introduction to slicing software

# Level

It is essential to level the print platform for 3D printing. For **ANYCUBIC** i3+, it is required to carry out the leveling manually. After the first time leveling, there is no need to do it again if the relative position keeps the same. The details explained as follows:

## 1、 Adjust the Z end stop position

Firstly, ensure the X axis is horizontal. Measure the distances between the left and right sides of X axis to the Z motor mounting plates, and make sure they are about equal, as shown in Figure(1).

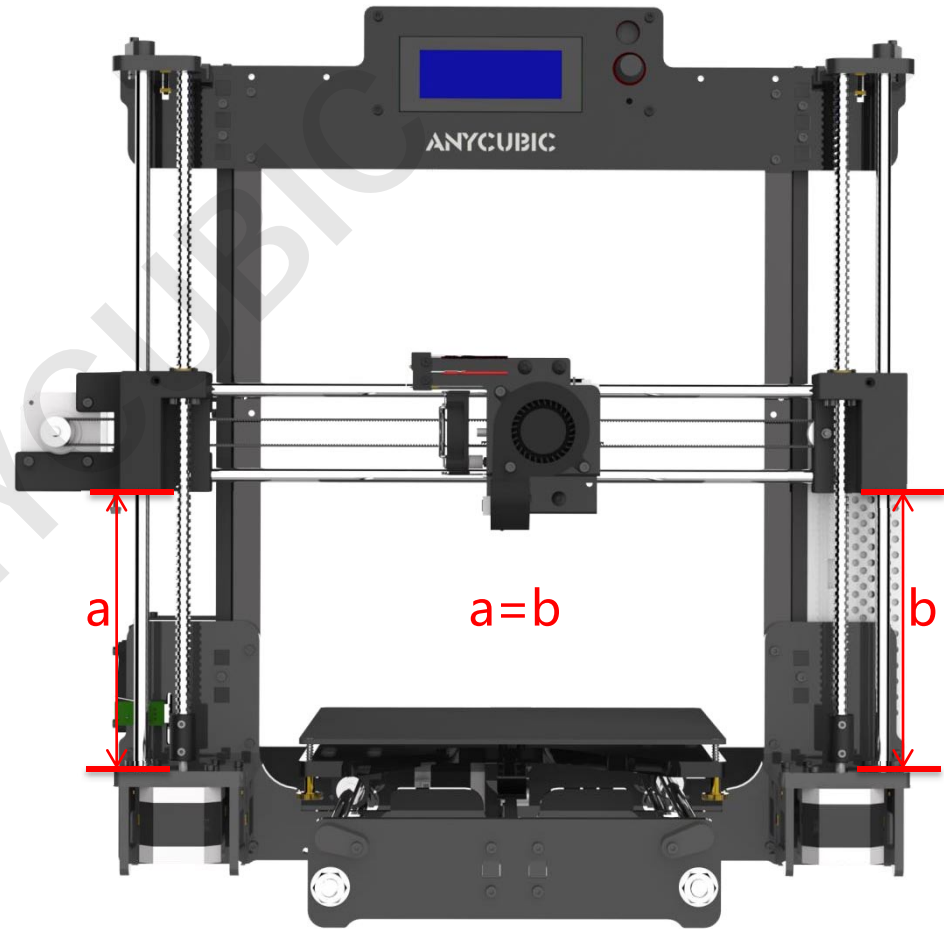

(1)

Secondly, press the knob on the display → “Prepare” → “Auto Home”, as shown in Figure(2).

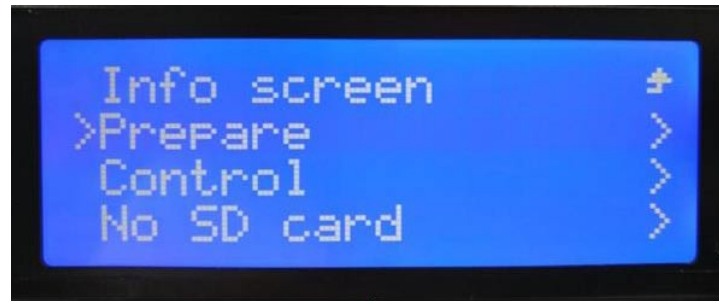

(2)

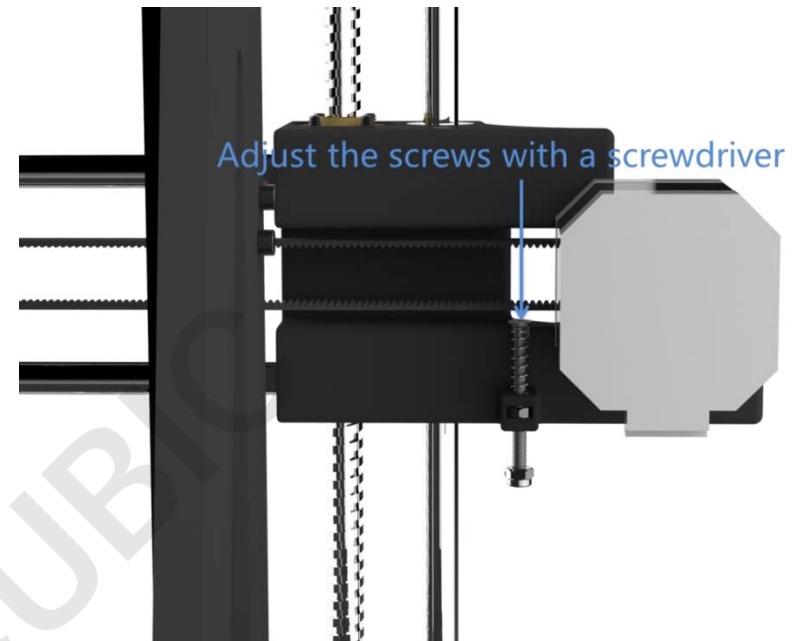

(3)

**Note: Be prepare to turn off the power immediately if the nozzle is hitting the platform and adjust the position of Z end stop, as shown in Figure(3).** Specifically, tighten (clockwise) it if nozzle below the platform, while loose (anti-clockwise) it if nozzle too far away from the platform. After adjustment, run “Auto Home” again until the nozzle is just ~1-2mm above the platform.

# Level

## 2、 Level

'Disable steppers' via 'Prepare'. Then, as shown in Figure(4)(5), put a piece of paper (e.g. A4 paper) onto the print platform, and then manually move the print head and platform back and forth : When the print head moving to corner ①, adjust (loosen or tighten) the corresponding adjustable nut underneath the platform to let the distance between the nozzle and platform close to the thickness of the paper (just feel the drag resistance when pulling the paper).

And then do the same for the rest ②③④⑤. After that, run 'Auto Home' and 'disable steppers' again, and move print head and platform back and forth to verify the leveling results.

**\*Do not let the nozzle directly rub against the platform, they must be separated by the paper.**

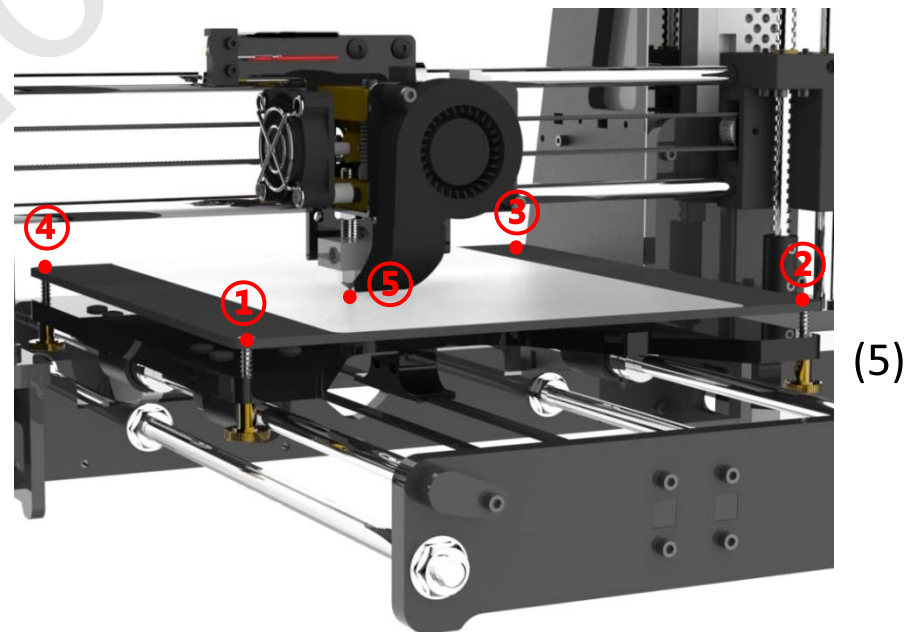
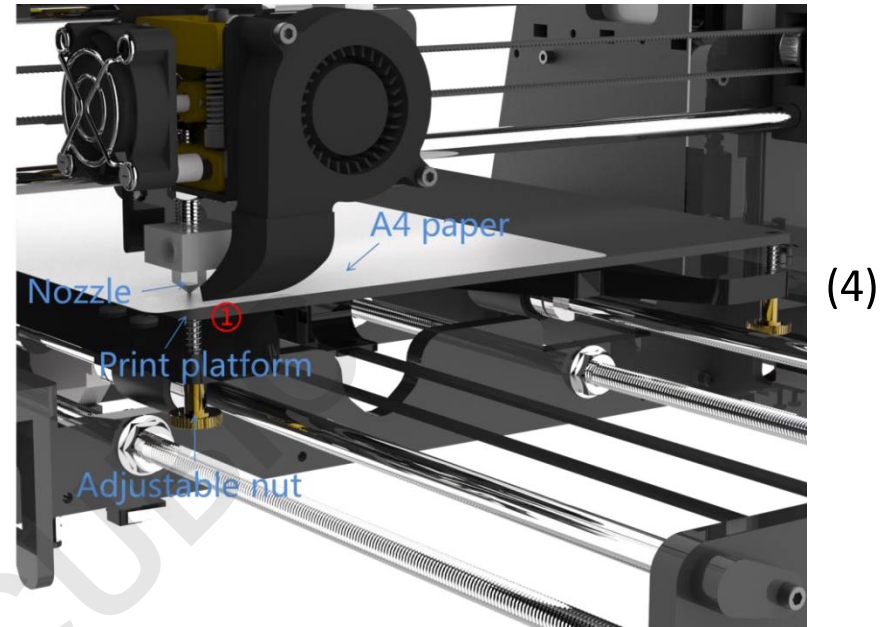

- Ideally, after 4 corners are leveled, the center area should be spontaneously leveled, and you may proceed to do a test print.
- However, please be mindful that, in some cases, the platform may not be perfectly flat (concave or convex) due to many factors.
- **ANYCUBIC** promises the print platform (**ANYCUBIC Ultrabase**) has the flatness in the range of 0~0.2mm variation, that means every piece of the print platforms has been tested by a 0.2mm feeler gauge (both sides of the platform have been respectively laid on a flat marble table and a 0.2mm feeler gauge could not be inserted in-between the platform and marble table).
- **ANYCUBIC Ultrabase** (a novel print platform) could be used for very long time without using masking tape, hair spray or glue stick. Besides, it is easy to remove the printed objects afterwards. Customers only have to clean it by alcohol or similar after every few prints.
- The suggested bed temperature for different filaments are show here: PLA: 50-70°C; TPU: 50-70°C; ABS: 90-120°C; PETG: 90-120°C; PP: 90-110°C; Nylon: 90-120°C; PC: 90-120°C. Please try several time until the most satisfying results.

## 3、 Install filament

Preheat the nozzle, choose “Prepare”--->“Preheat PLA” on screen menu. When reaches the target temperature, we should press the handle on the extruder by hand and push the filament until it melt through the nozzle, as shown in Figure(6)(7). Use tweezers to carefully get rid of the melted filament at the nozzle tip.

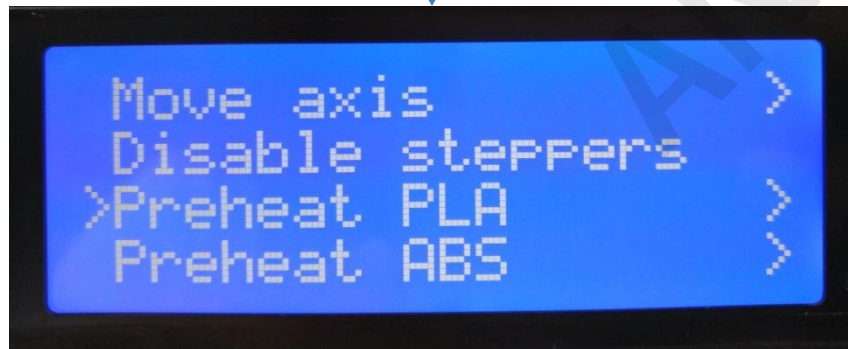
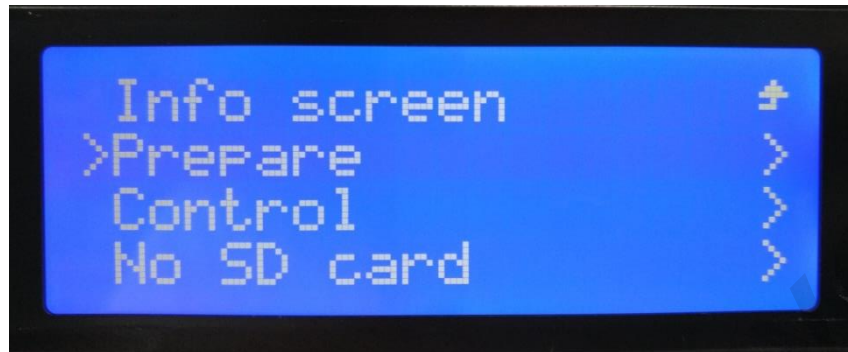

(6)

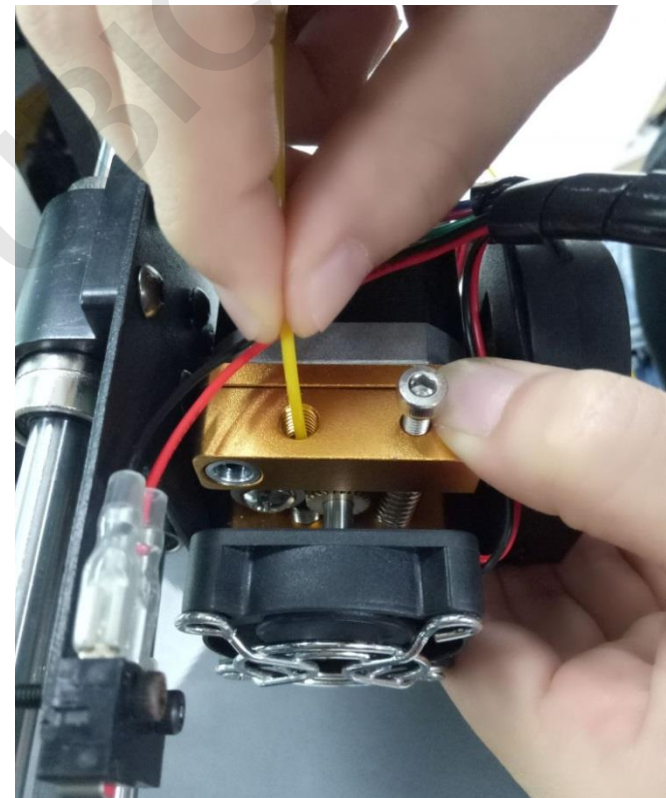

(7)



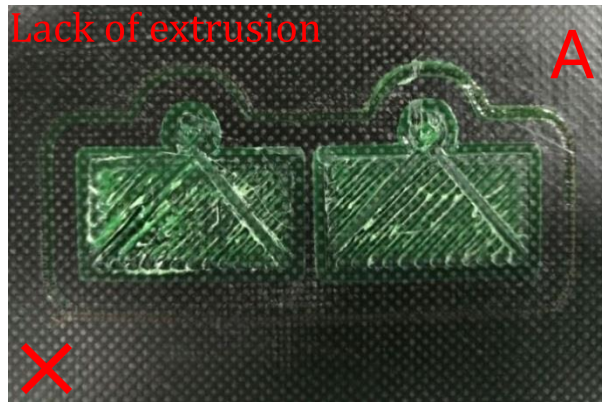

Nozzle too close

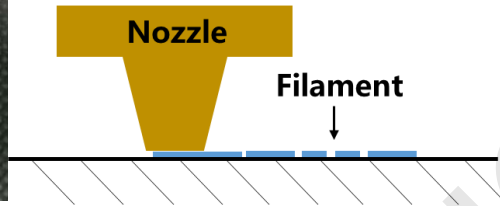

Proper nozzle height

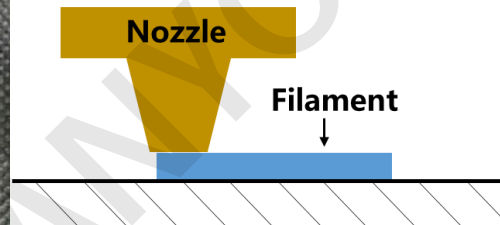

Nozzle too high

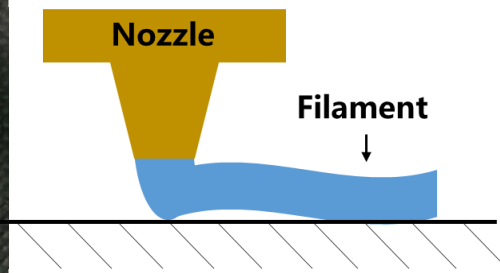

## 4、 Test print

Insert the SD card into the SD card slot (on the back of LCD display). Click on the knob, there is a printable test file include: "owl\_pair" (author : etotheipi , [www.thingiverse.com](http://www.thingiverse.com)).

There might be 3 kinds of results for the first layer of the test prints. Raise the Z axis by 10mm first then do the adjustments.

When the result is shown in Figure A, tighten the adjustable nut;

When the result is shown in Figure C, loosen the adjustable nut;

It may need adjustment for few times until satisfying results such as Figure B.

# Driver installation

There are two operational mode for **ANYCUBIC** i3+ 3D printer : print offline, print online.

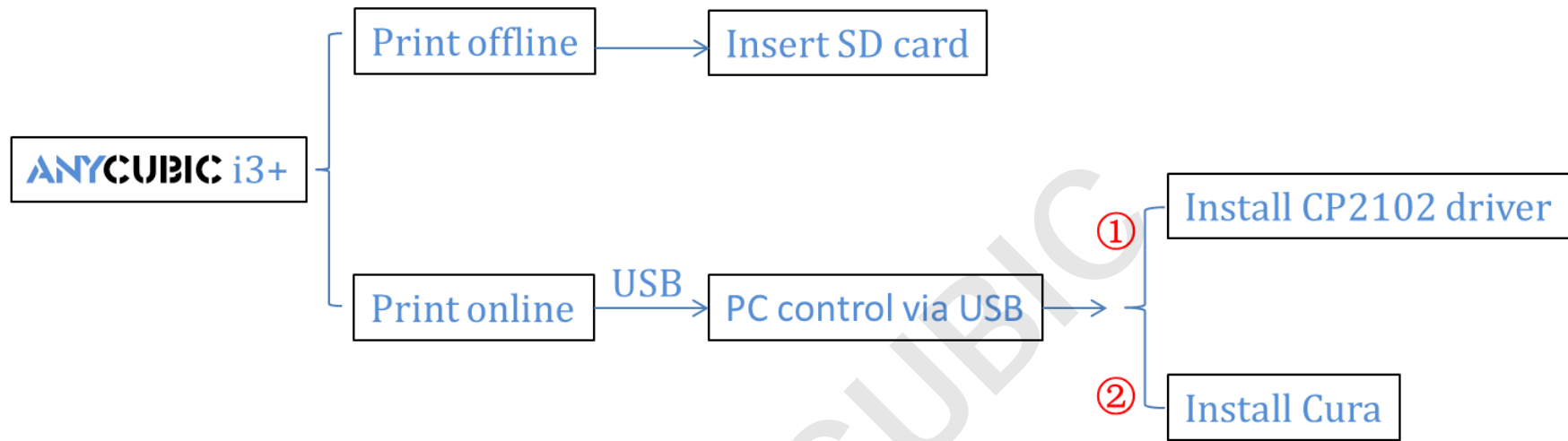

**Print offline:** After leveling the platform, insert SD card, click “Print from SD” on LCD and select a file (Gcode files ONLY) to print.

**Print online:** Install CP2102 driver to bridging PC and machine, and install Cura for slicing and control the machine via USB.

Generally, it is suggested to use Print offline to minimize the noisy signal via USB.

# Driver installation

First, turn on the machine, use the USB cable to connect the printer (mainboard USB port) and your PC. **ANYCUBIC** i3+ 3D printer uses CP2102 chip for communication. The CP2102 driver may not be installed automatically, so we should check it: Right click “This PC” --- “Properties” --- “Device manager”, if there is an exclamation mark as shown below, then you need to install the driver manually.

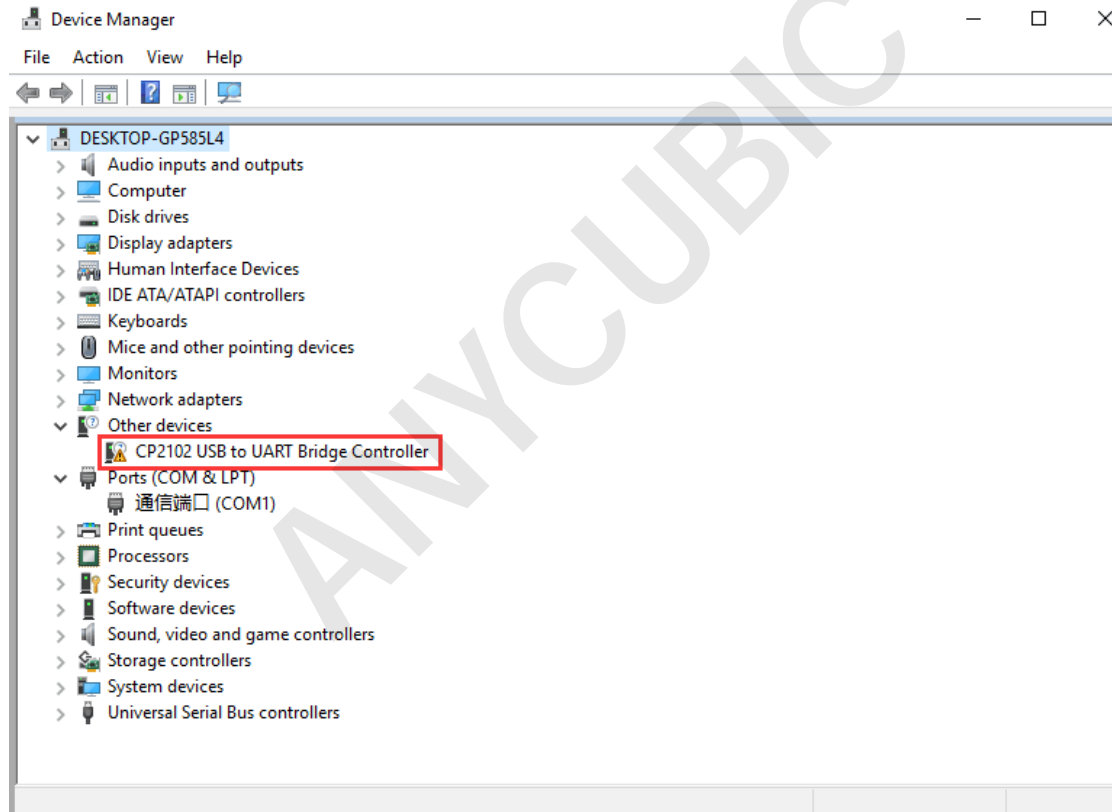

# Driver installation

CP2102 driver files are located in the SD card. “Files\_English\_i3+”---“Driver\_CP2102”---“Windows” (“CP210xVCPInstaller\_x64” is for 64 bit system and “CP210xVCPInstaller\_x86” is for 32 bit system). Here we take Windows 7 64 bit PC system for example:

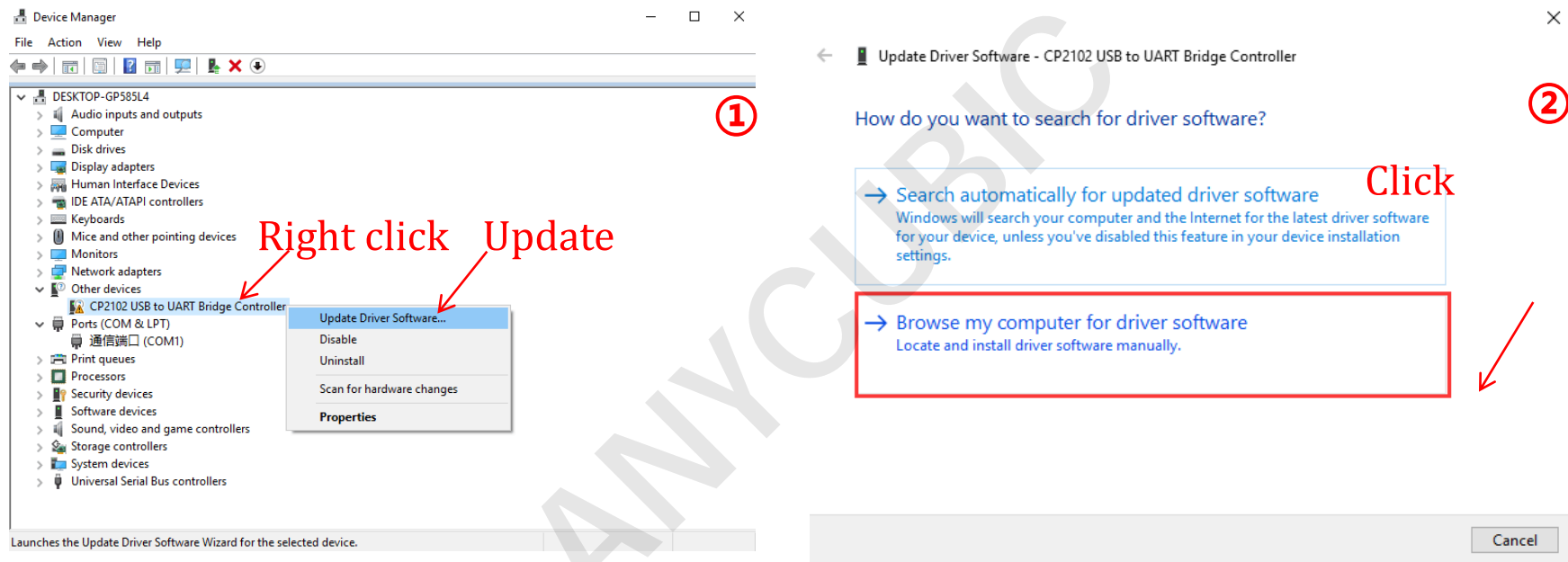

# Driver installation

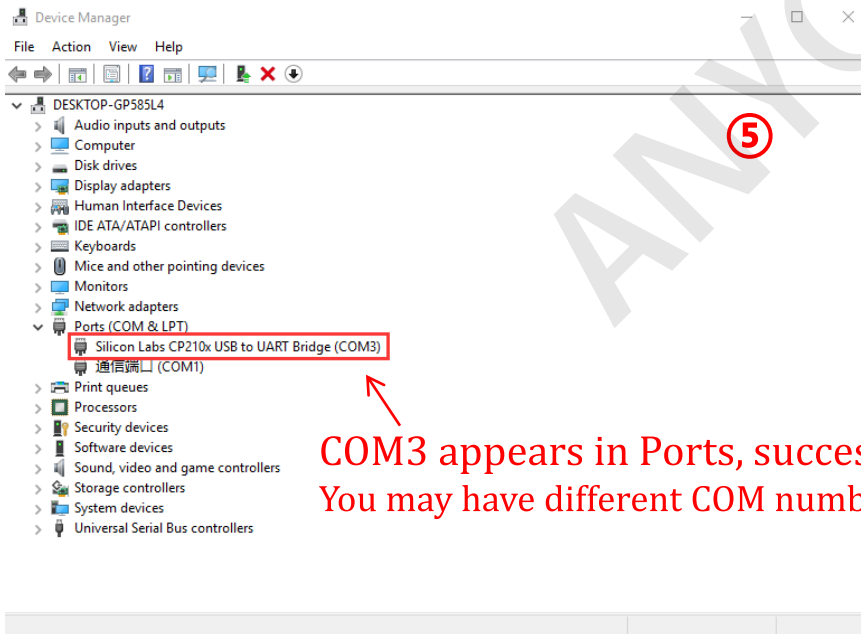
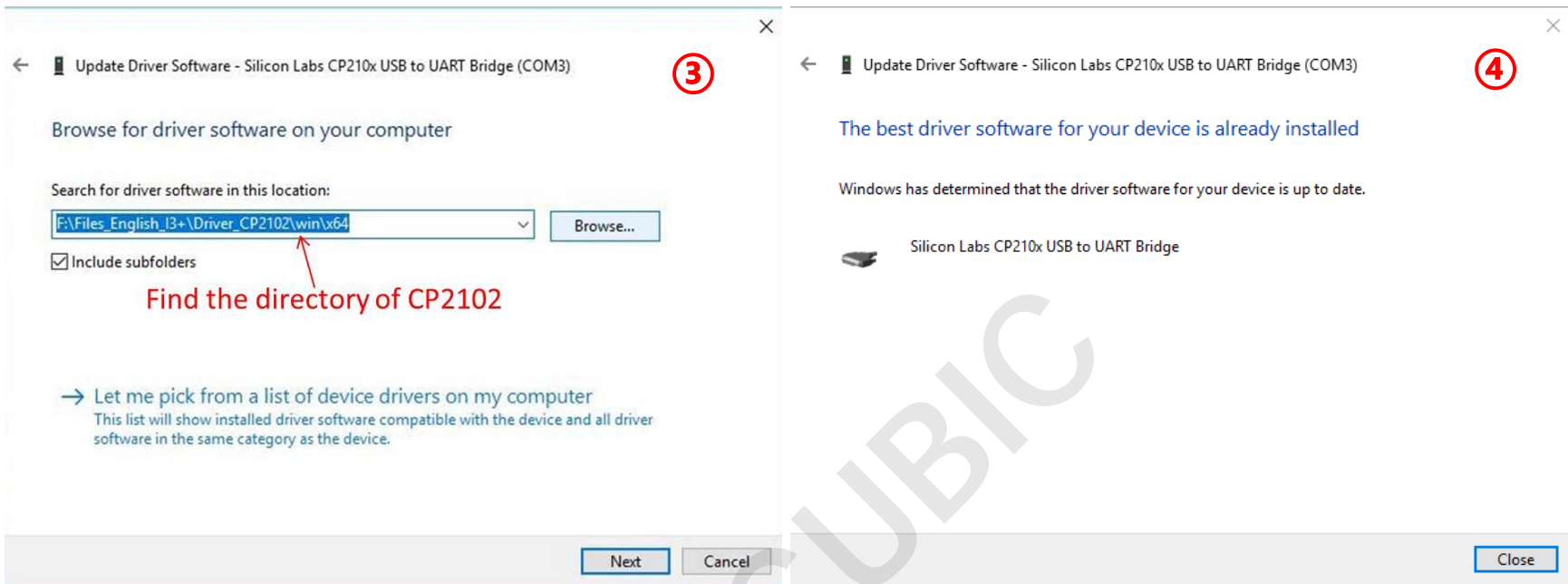

# Introduction to slicing software

## 3.1、 Cura installation

Cura15.04.6 is used for example. It is located in SD card→“ Files\_English\_i3+”→ “ Cura”→ “ Windows”. Double click “Cura\_15.04.6”, and follow the steps as shown below.

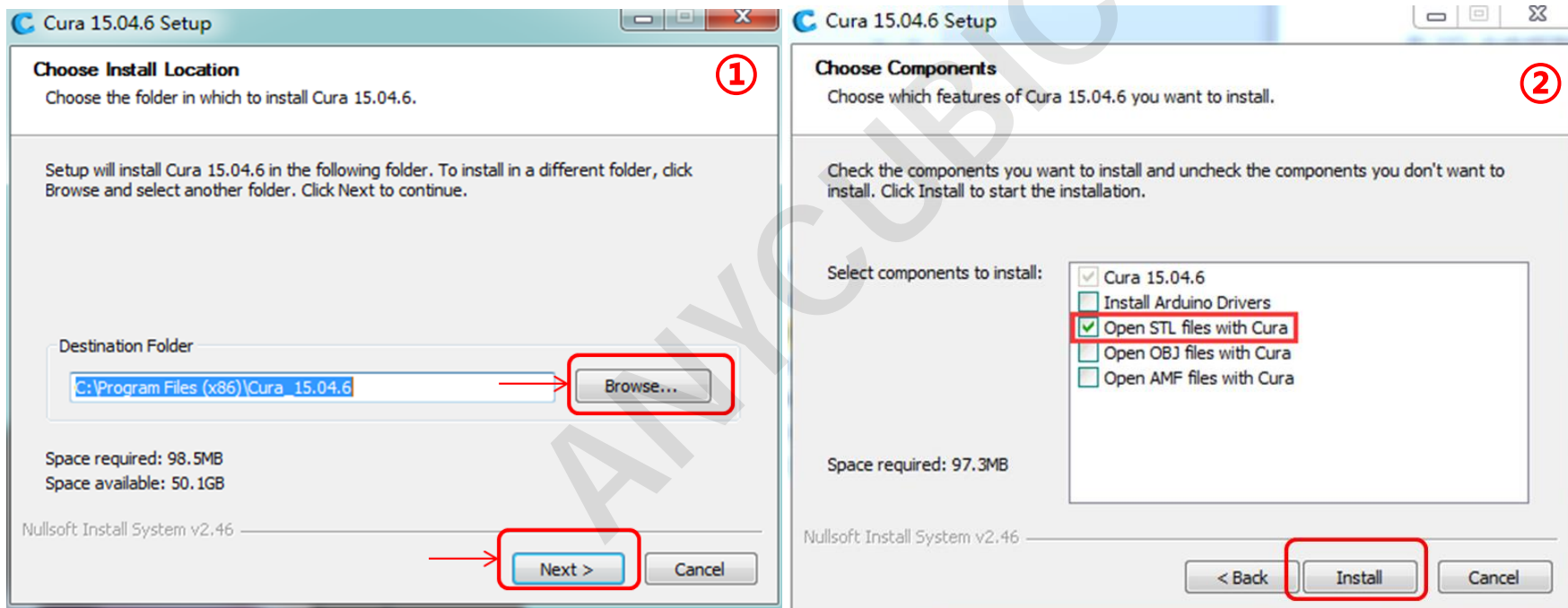



# Introduction to slicing software

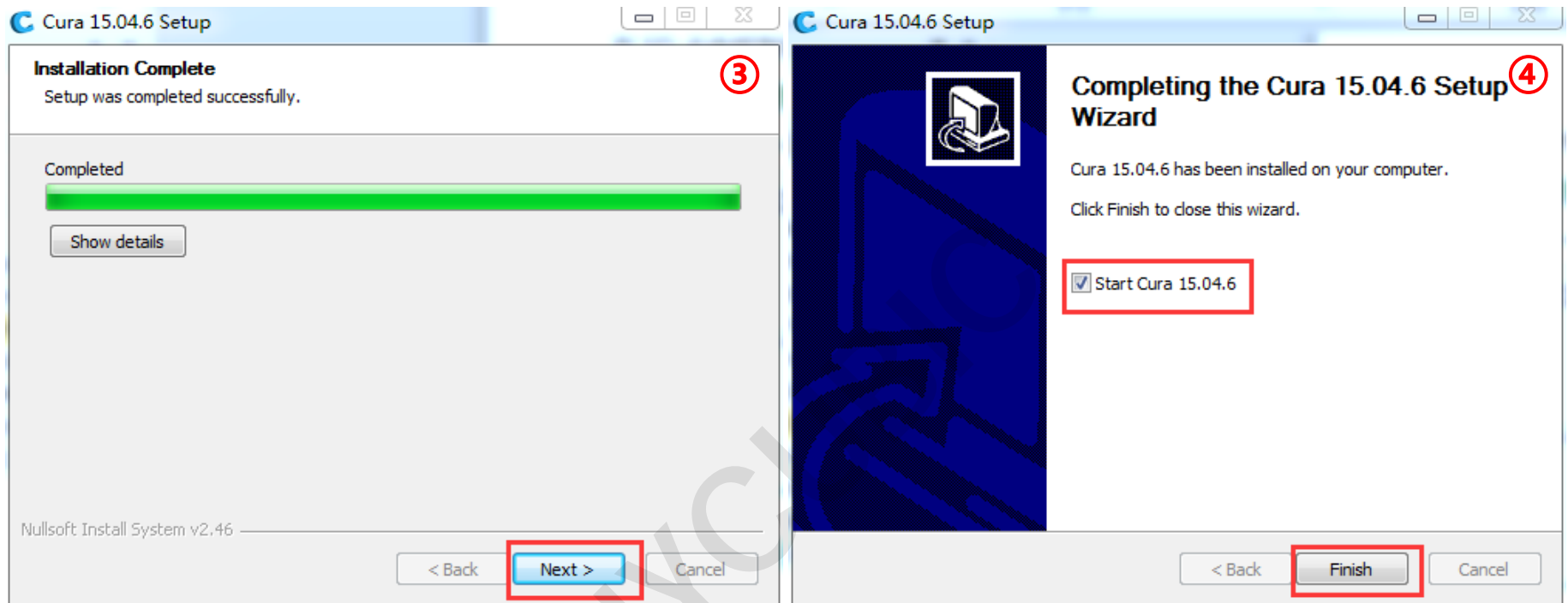

Next, before start Cura for the first time, there will be more settings about the language and machine types, as shown below:

# Introduction to slicing software

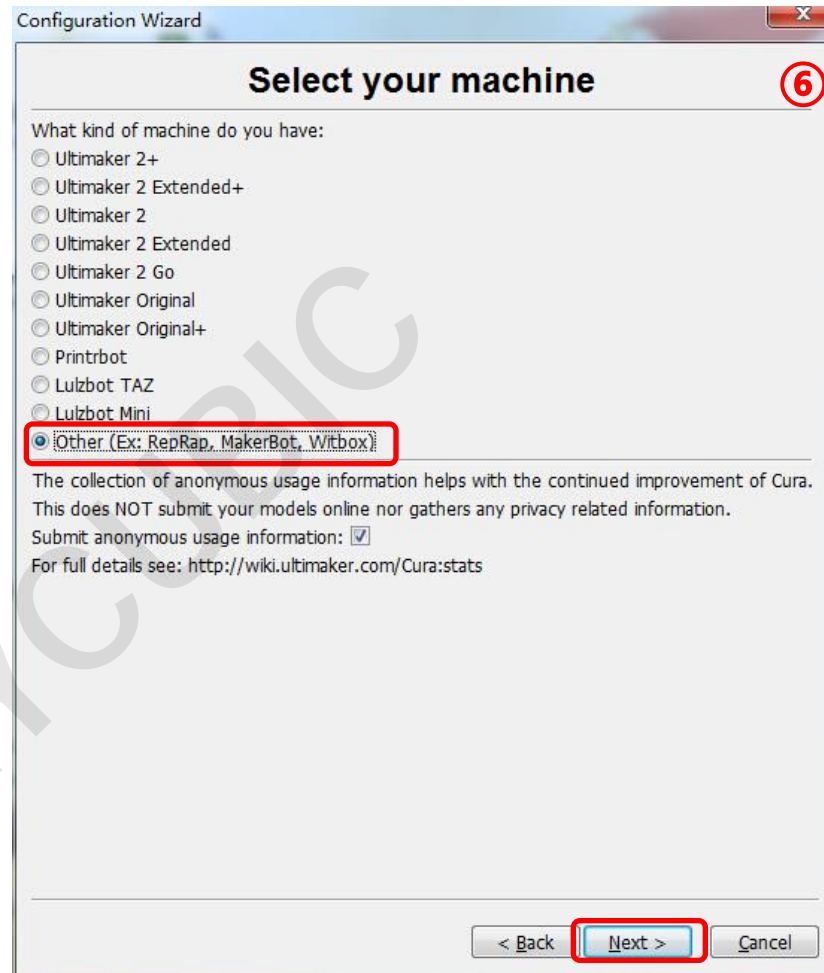

# Introduction to slicing software

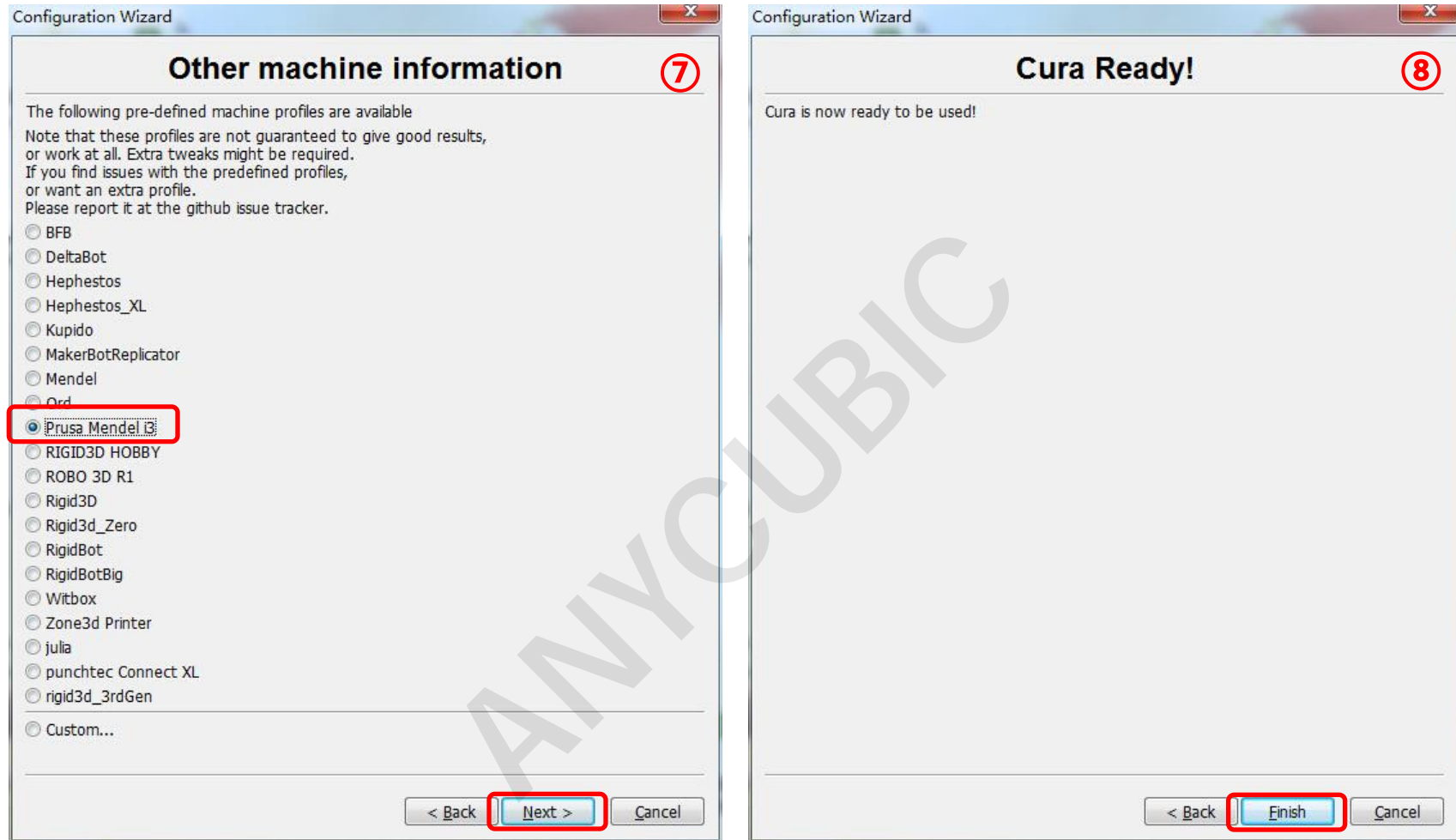

Upon finish, open Cura for the first time, there might be a default robot model appears, customers may click “File”→ “Clear platform” to delete it.

# Introduction to slicing software

## 3.2、 Manipulate 3D model in Cura

In the Cura software interface, click on the “file” → “Load model file” to import your own three-dimensional format model (such as .stl file). Users can “Rotate” “Scale” “Mirror” the model. As shown below:

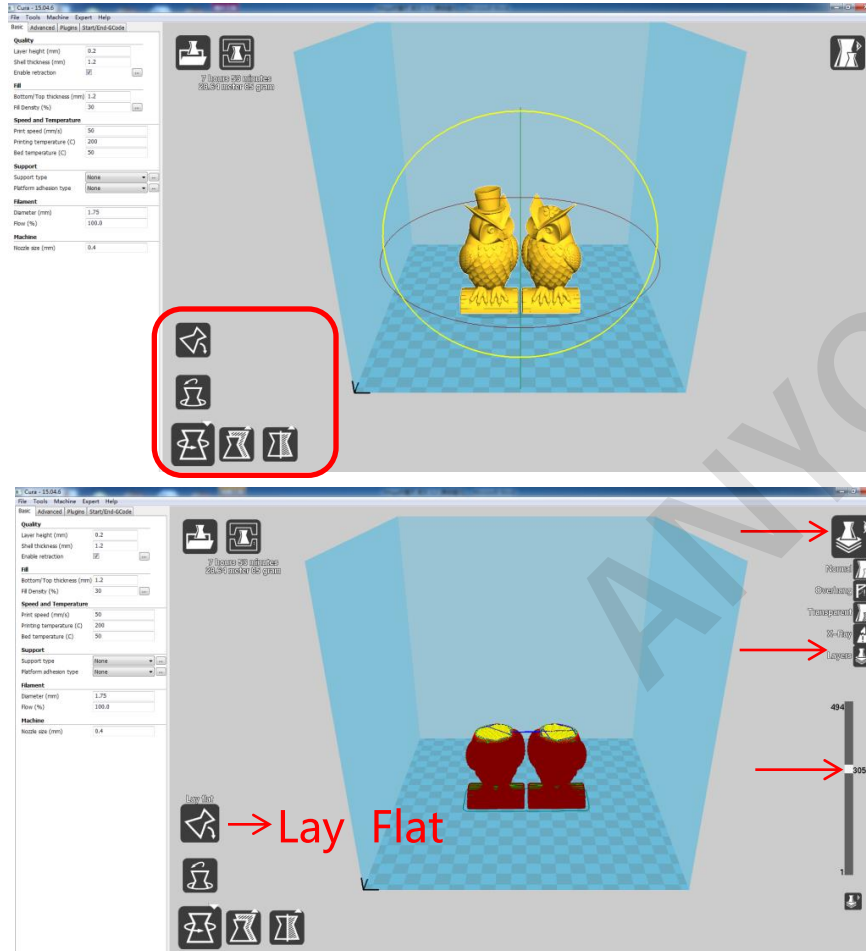

### Other operations:

- (1) Change viewing angle : right click the model, hold on and move the mouse.
- (2) Zoom in/out : scroll the mouse wheel.
- (3) Position change : left click on the model, hold on and drag the model to move.
- (4) After rotating the model, it is strongly recommended to click on the 'Lay Flat' icon to ensure that flat portion of the model is well attached to the platform.

# Introduction to slicing software

## 3.3、 Cura settings

(1) In the menu bar, select “machine” → “machine settings”. Please choose the same Serial Port (COM) as shown in your PC → Device Manager→ Port (customers may have a different COMx other than the example COM3 below, and set the Baudrate to 250000).

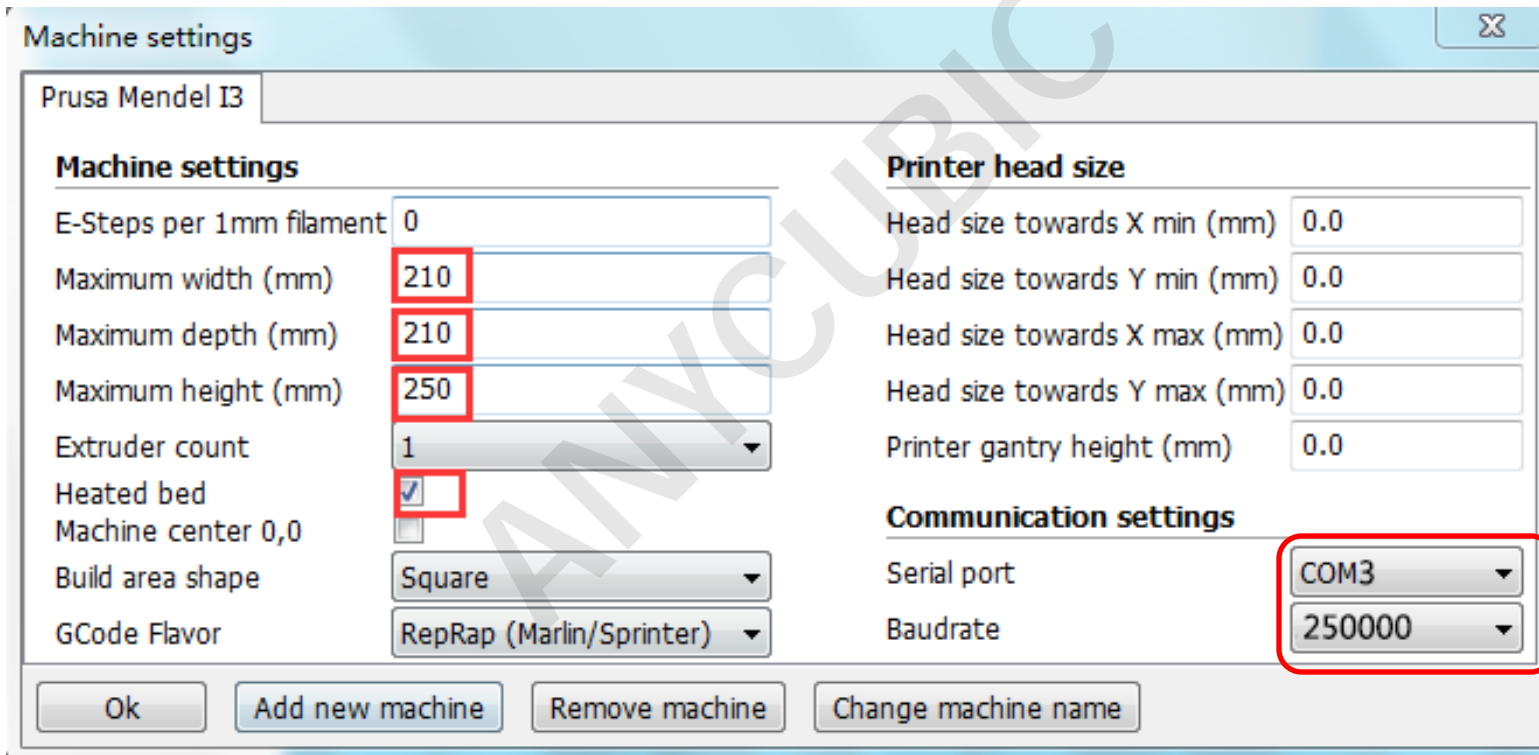

# Introduction to slicing software

(2) Click “OK” for the setting to return to the main interface, and then set the “Basic” and “Advanced” parameters separately, as shown below:

Category	Parameter	Value
Quality	Layer height (mm)	0.2
	Shell thickness (mm)	1.2
	Enable retraction	<input checked="" type="checkbox"/>
Fill	Bottom/Top thickness (mm)	1.2
	Fill Density (%)	30
Speed and Temperature	Print speed (mm/s)	60
	Printing temperature (C)	195
	Bed temperature (C)	50
Support	Support type	None
	Platform adhesion type	None
Filament	Diameter (mm)	1.75
	Flow (%)	100.0
Machine	Nozzle size (mm)	0.4

Category	Parameter	Value
Retraction	Speed (mm/s)	60
	Distance (mm)	6
Quality	Initial layer thickness (mm)	0
	Initial layer line width (%)	140
	Cut off object bottom (mm)	0.0
	Dual extrusion overlap (mm)	0.15
Speed	Travel speed (mm/s)	60
	Bottom layer speed (mm/s)	20
	Infill speed (mm/s)	0.0
	Top/bottom speed (mm/s)	20
	Outer shell speed (mm/s)	30
	Inner shell speed (mm/s)	40
Cool	Minimal layer time (sec)	5
	Enable cooling fan	<input checked="" type="checkbox"/>



# Introduction to slicing software

## Attention:

**Layer height:** determine the important parameters for print quality, usually set to 0.1-0.3.

**Shell thickness:** usually set to a multiple of the nozzle diameter.

**Fill density:** The larger the parameter, the more solid the model is.

**Print speed:** printing too fast may make printer shaky, 30-60 is suggested.

**Printing temperature:** PLA should be 190-210°C, and ABS should be 230-240°C.

**Filament diameter:** 1.75mm.

**Nozzle size:** 0.4mm.

**Retraction speed:** Increasing the retraction speed and distance can reduce the stringing problem, but set it too high may cause clogging.

**Travel speed:** 60mm/s is suggested, the printing accuracy would be affected if it is too fast.

**Outer shell speed:** Reducing the outer shell print speed would create a more smooth model surface.

# Introduction to slicing software

## 3.4、 Print online

After the parameters have been set up, you can print online via Cura.

As shown below, click on the upper left corner "File" ---> "Print", Cura will automatically connect to the printer. The user can click "Print" icon when it is available. Then the temperature would rise and it will start to print when reaching to the target temperature. Use tweezers to carefully get rid of the pre-extruded filament at the nozzle tip.

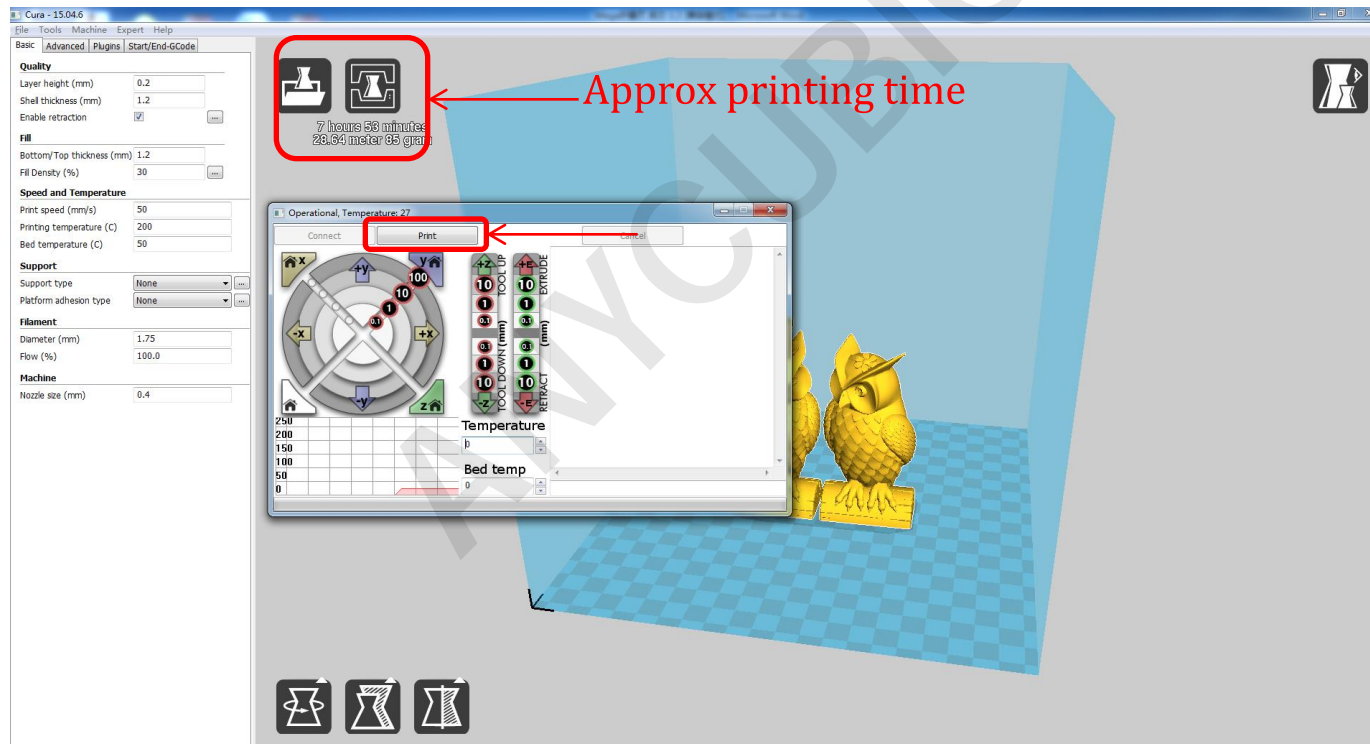

## 3.5、 Print offline

After completing all the parameter settings, click on the Cura software main interface "File" → "Save Gcode". Save the model Gcode file to the SD card, and then use the SD card for offline printing.

**Note:** the file name should only contain English letters, underscore and space. File name contains special characters could not be recognized by the printer.

ANYCUBIC

# FAQ

- Machine
- Printing

ANYCUBIC

## 1. Machine

### 1. PC cannot identify the mainboard

Please refer to Setup/Print section and re-install the driver if necessary.

### 2. Slicing software cannot communicate with printer

Ensure the serial port (not Auto) is correct. And the baud rate is 250000.

### 3. Extruder or hot bed fails to heat

Please check the power and the thermistor connection.

### 4. Motors malfunction

- ① Motor do not work. Please check motor wires, motor drives, and the power supply.
- ② Motor shakes. Motor driver has not been installed well, or the motor wires have not been connected steady.
- ③ Motor goes in one direction. Please check the limit switch wiring or if there is any interference.

## 5. Blue screen

Make sure EXP1 to EXP1, EXP2 to EXP2. Please adjust the contrast of LCD (on its back).

## 6. Unsmooth feeding

- ① Printing head jammed.
- ② The throat tubing is clogged, swap it or clean it using cleaning needles
- ③ Material leaks out of the printing head. The nozzle has not been tightening well.
- ④ Inspect if the heating temperature is set too low for the filament.

## 7. Unable to print offline

Ensure the SD card is OK; Gcode files is the only format to print offline, and the file name should be in English.

## 8. Lack of extrusion

The printing head jams ◇ Layer set too small ◇ Poor quality filament ◇ Nozzle diameter is not set correctly



## 2. Printing

### 1. Warping

Platform not leveled well ◇ The nozzle is too far from the platform ◇ Filament problem (ABS filament shrinkage is very strong) ◇ The first layer printed too fast

### 2. Stringing

The retraction speed and distance are set small ◇ Print temperature setting is too high ◇ Poor quality filament

### 3. Layer Separation

Drive current is too small ◇ Print too fast ◇ Structural/assembly problems

### 4. Lines on the side of print

Z axis is not assembled well ◇ Extrusion instability ◇ Temperature fluctuation

The above is some common problems and solutions. Please contact us if you have any other question about the products, we are likely to solve all the problems for you.

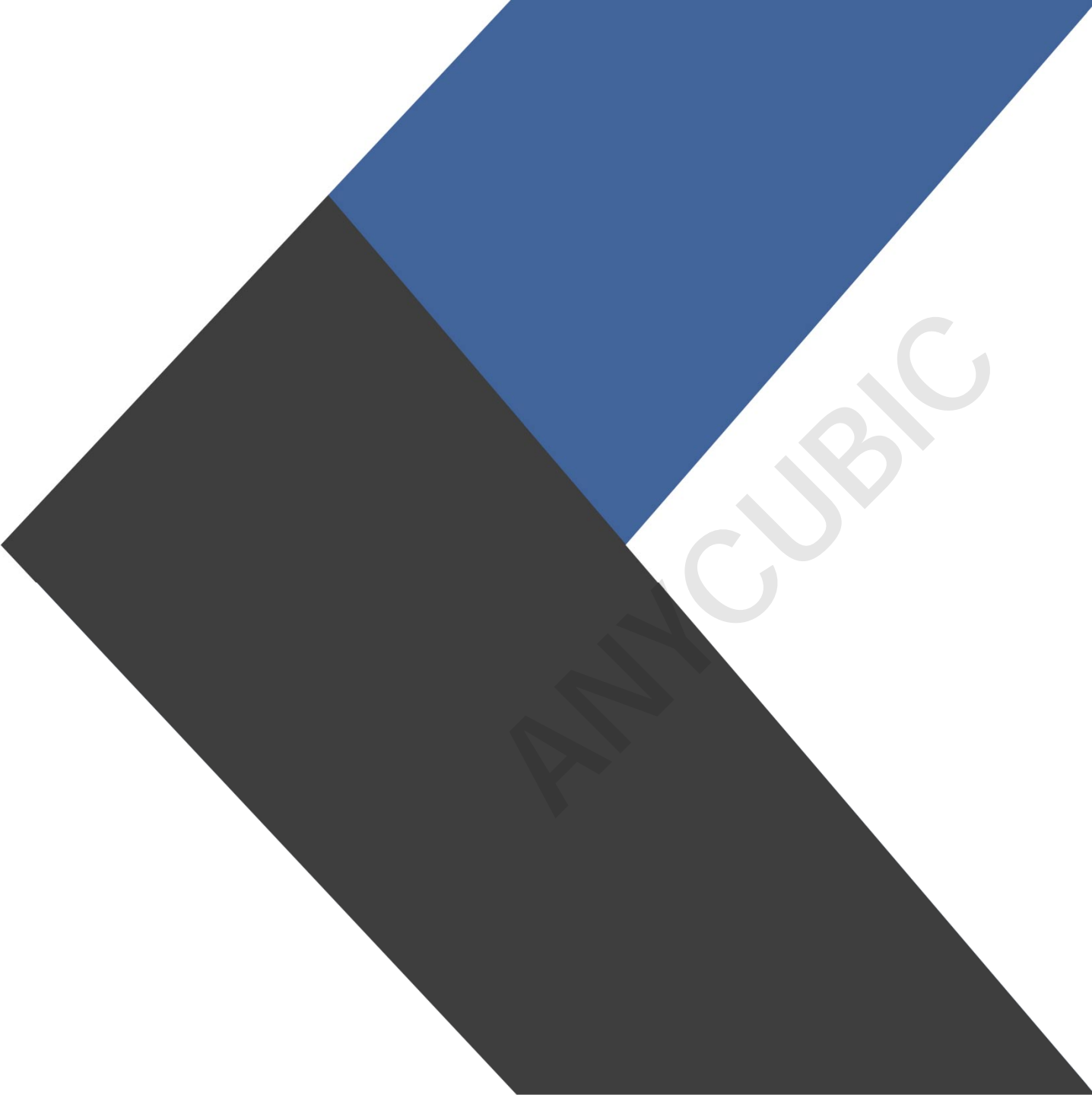

ANY CUBIC



IOT003